

PTC[®] PRODUCT & SERVICE ADVANTAGE



PTC Creo 3.0 Update

Christoph von Andrian-Werburg
Director, CAD Segment Europe

Malmö, October 15th



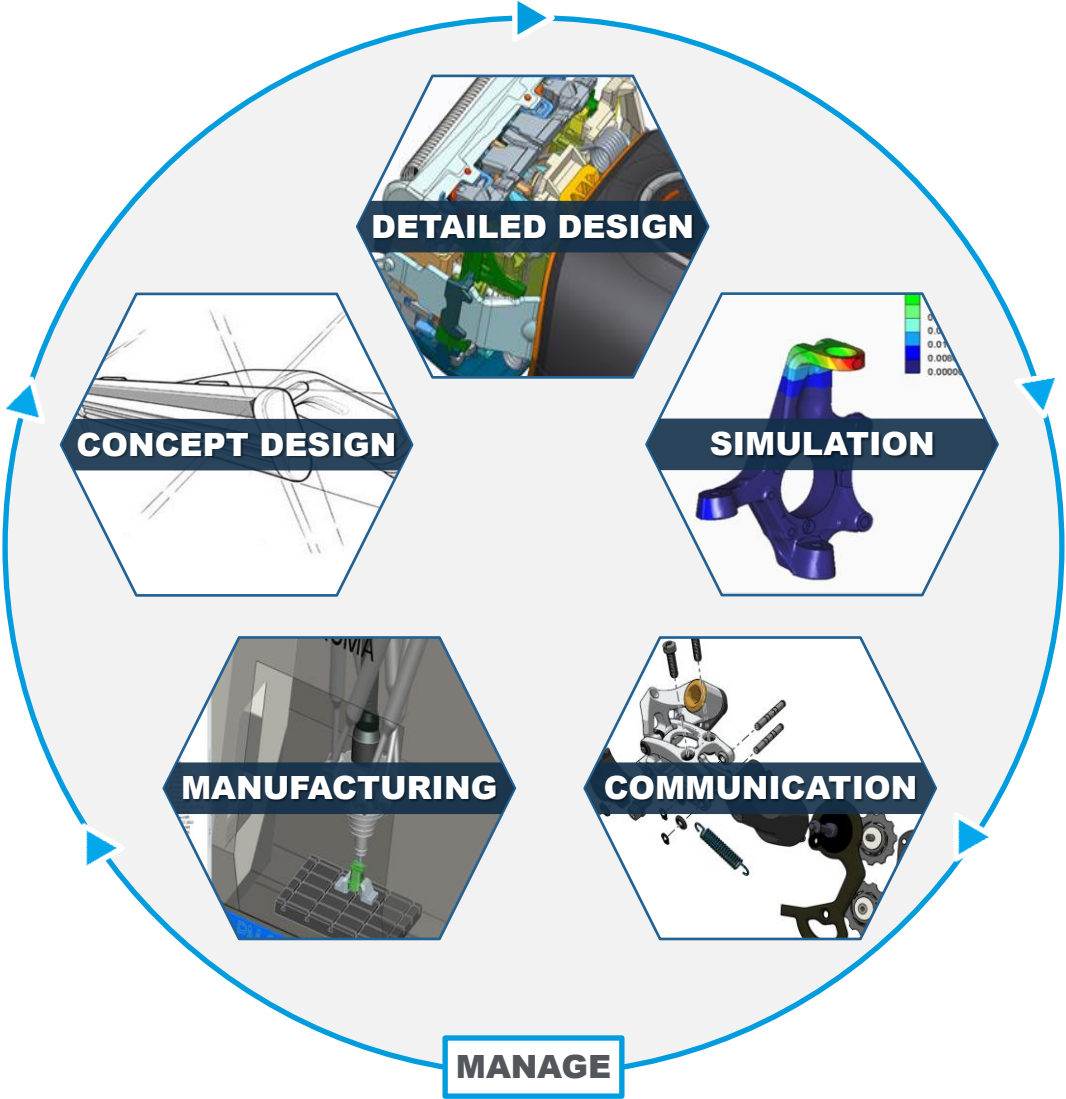

a **scalable, interoperable** suite of product design software that delivers **fast time to value**

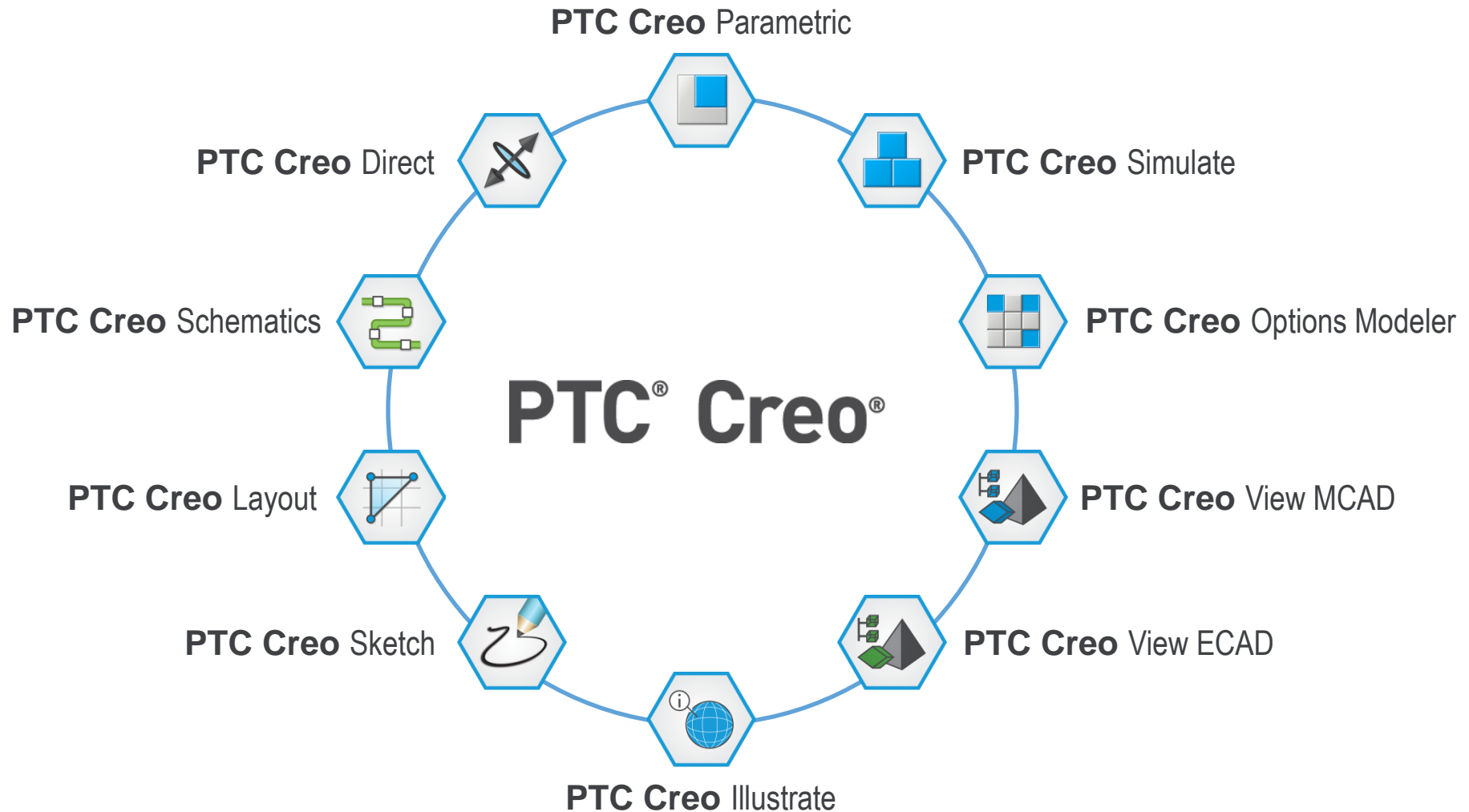



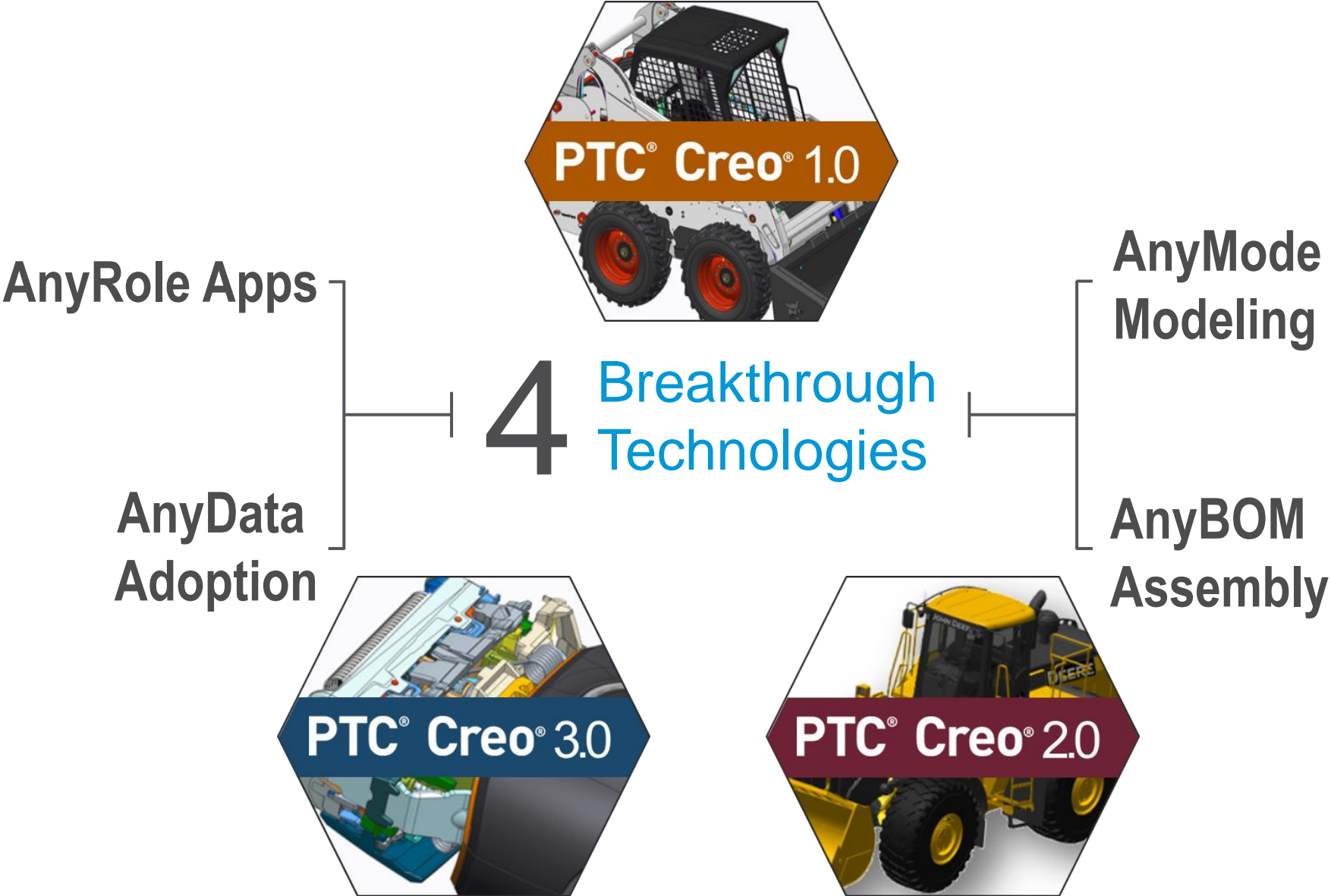

Breakthrough Multi-CAD Technology



**Unite
Technology**

Concept Design Improvements



**Empowering
Innovation**

PTC Creo Efficiency Improvements

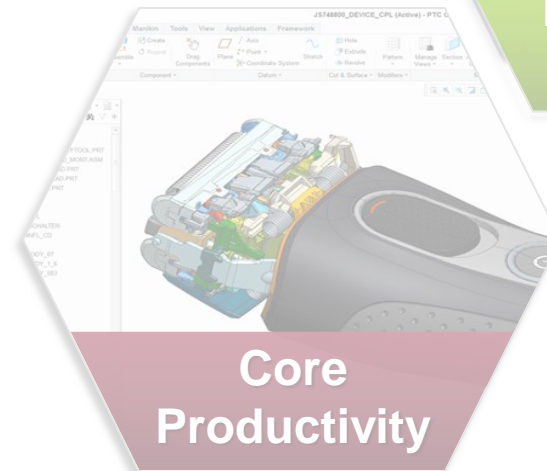

**Core
Productivity**

- **PTC Creo Unite Technology**
 - Breakthrough capabilities to improve productivity in Multi-CAD environments
- **Key Unite Technology Use Cases**
 - Consolidation
 - Consolidate to a single CAD system with ease
 - Collaboration
 - Collaborate effectively in a Multi-CAD environment
- **Format Specific Details**
- **Summary & Benefits**



Enabling Optimal Multi-CAD Collaboration and Consolidation

- **Import** common 3D CAD formats
 - SolidWorks, CATIA, NX, Solid Edge, Inventor formats
- **Open** key 3D CAD formats
 - SolidWorks, CATIA, NX formats
- **Automatically update** new versions of non-PTC Creo data within your designs
- **Save As** key 3D CAD formats
 - SolidWorks, CATIA, NX formats



File Model Analysis Annotate Render Manikin Tools View Applications Framework

Regenerate Assemble Drag Components Plane Axis Point Coordinate System Sketch Hole Extrude Revolve Pattern Manage Views Section Appearance Gallery Display Style Component Interface Publish Geometry Family Table Bill of Materials Reference Viewer

Operations Get Data Component Datum Cut & Surface Modifiers Model Display Model Intent Investigate

Navigation and manipulation icons: pan, rotate, zoom, translate, etc.

Model Tree

- JS488488_SHAVER_DEVICE.ASM
 - ASM_RIGHT
 - ASM_TOP
 - ASM_FRONT
 - ASM_DEF_CSYS
 - JS748800_DEVICE_CPL.ASM
 - JS5184_HEAD_DEVICE.ASM
 - Placement
 - ASM_RIGHT
 - ASM_TOP
 - ASM_FRONT
 - ASM_DEF_CSYS
 - Insert Here
 - Insert Here
 - Sections
 - XSEC0001

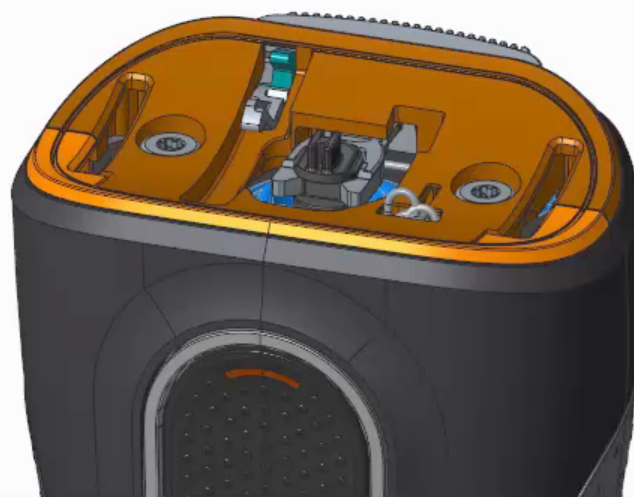

PTC Creo 3.0 supports CAD consolidation:

- **Import** common 3D CAD formats
 - SolidWorks, CATIA, NX, Solid Edge, Inventor formats
- **Open** key 3D CAD formats
 - SolidWorks, CATIA, NX formats
- **Automatically update** new versions of non-PTC Creo data within your designs
- **Save As** key 3D CAD formats
 - SolidWorks, CATIA, NX formats

Consolidate CAD systems to improve quality, speed time to market and lower costs for both Engineering and IT

CONSOLIDATION

BEST IN CLASS COMPANIES ARE 35% MORE LIKELY TO STANDARDIZE ON ONE CAD SYSTEM¹



¹ Working with Mult-CAD? Overcoming the Engineering Collaboration Bottleneck – Aberdeen Group

Unite Technology Addresses the Challenges of Data Migration

Save time and money with an effective convert as needed workflow

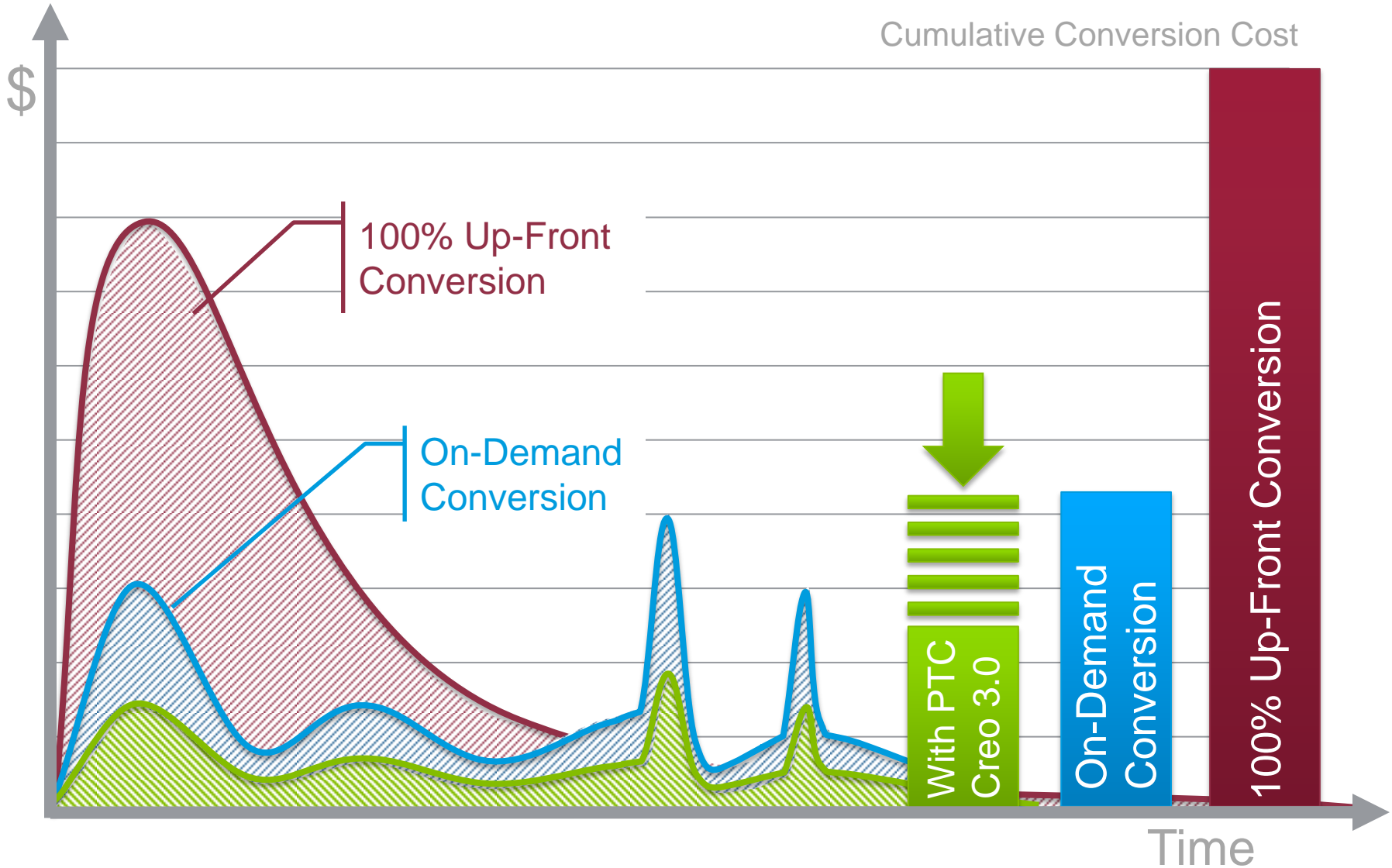

Save time and money with an effective convert as needed workflow

The PTC Creo Unite Technology converts only on-demand the necessary non-PTC Creo components into PTC Creo components.

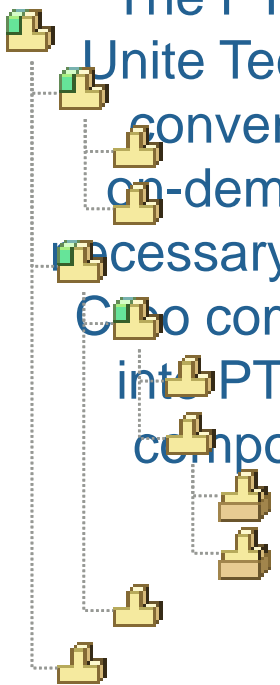

Open

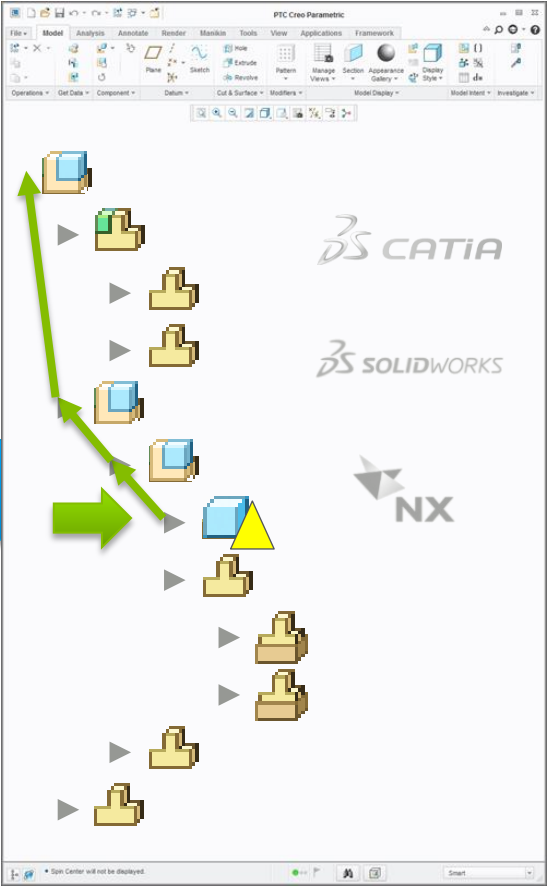

Import

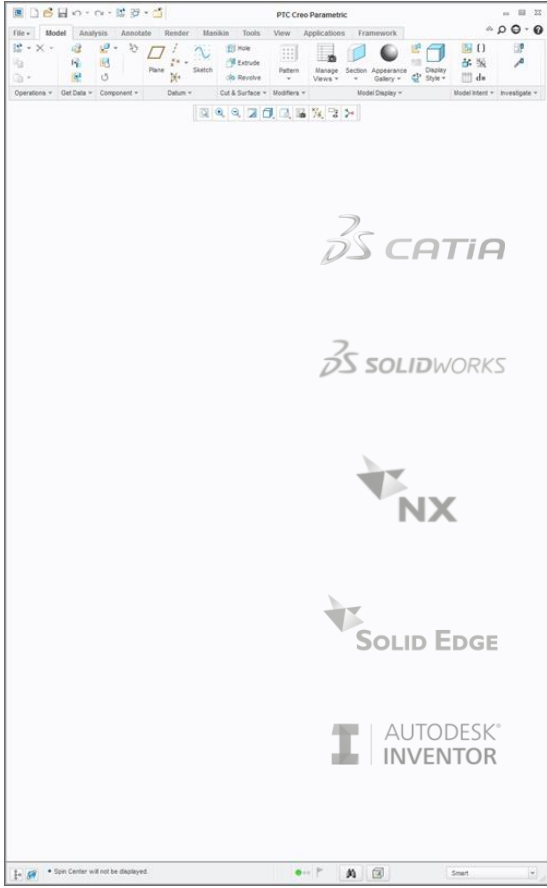

Benefits

- Convert Data as needed, when needed
- Easily re-use legacy 2D and 3D data with minimal PDM effort
- Reduce # of CAD platforms and the associated costs of Software Licenses, Support and Training
- Increase Engineering Productivity and IT Efficiency
- Enable a “Design Anywhere, Build Anywhere” strategy

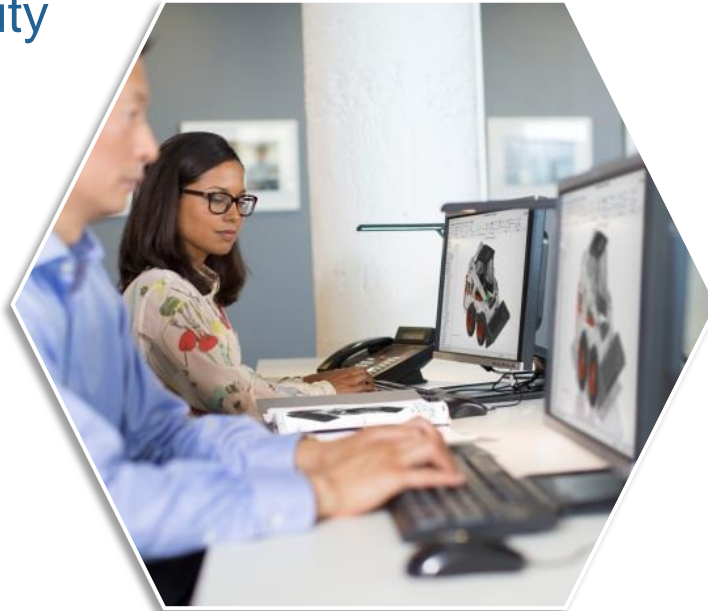

PTC Creo 3.0 supports CAD Collaboration:

- **Import** common 3D CAD formats
 - SolidWorks, CATIA, NX, Solid Edge, Inventor formats
- **Open** key 3D CAD formats
 - SolidWorks, CATIA, NX formats
- **Automatically update** new versions of non-PTC Creo data within your designs
- **Save As** key 3D CAD formats
 - SolidWorks, CATIA, NX formats

59% OF PEOPLE HAVE
DIFFICULTY MANIPULATING
IMPORTED MODELS²

COLLABORATION

Support more effective
product development and
drive on-time delivery by
working more efficiently with other
departments, suppliers or
development partners.



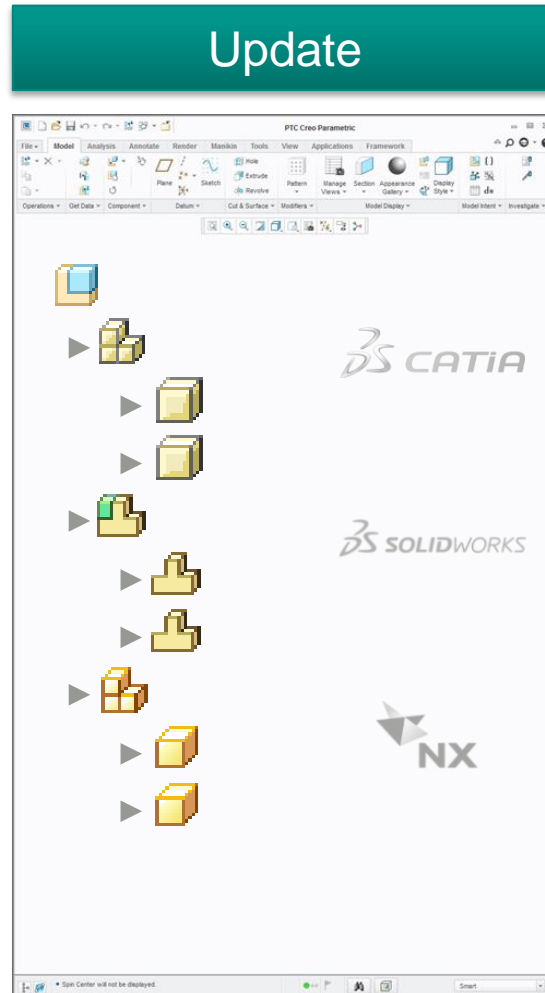
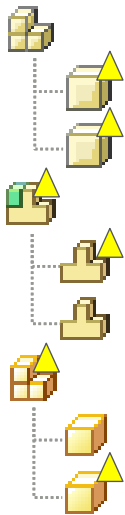

With the PTC Creo Collaboration Extensions, you can easily update and incorporate changes from SolidWorks, CATIA or NX formats.

With the PTC Creo Collaboration Extensions, you can easily save your data in SolidWorks, CATIA or NX formats.

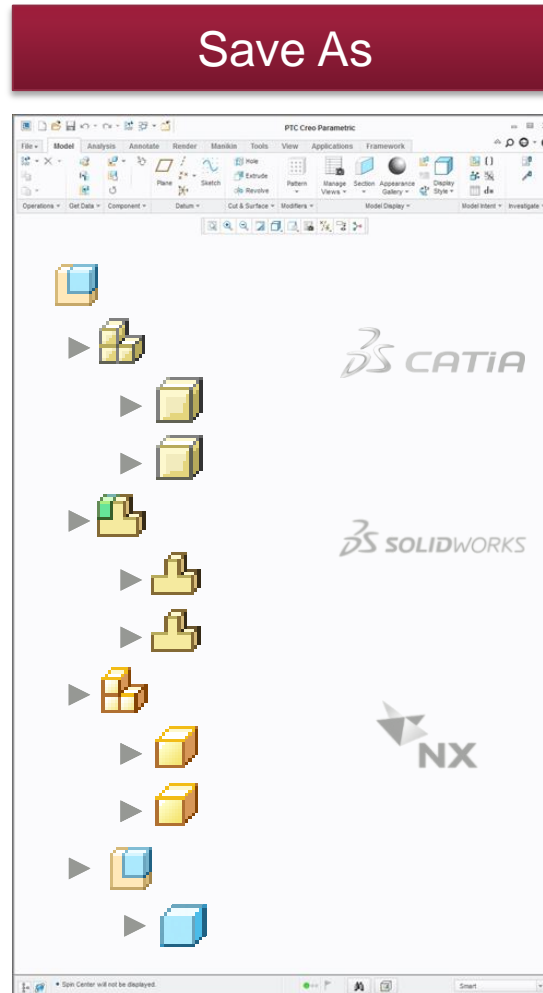

PTC Creo Unite Technology enables Superior Collaboration

- Update and Save As Key 3D CAD Formats
- Build Better Designs
 - Start collaborating between Multi-CAD design teams early
 - Design in Context of Multi-CAD assemblies with confidence
 - Build design intent across 3D CAD formats easily
 - Keep all models updated
- Complete Enterprise Process Coverage
 - Build associative drawings
 - Build associative structural, thermal, dynamic analyses
 - Build Multi-CAD modular product architecture
 - Full support of downstream manufacturing and documentation processes



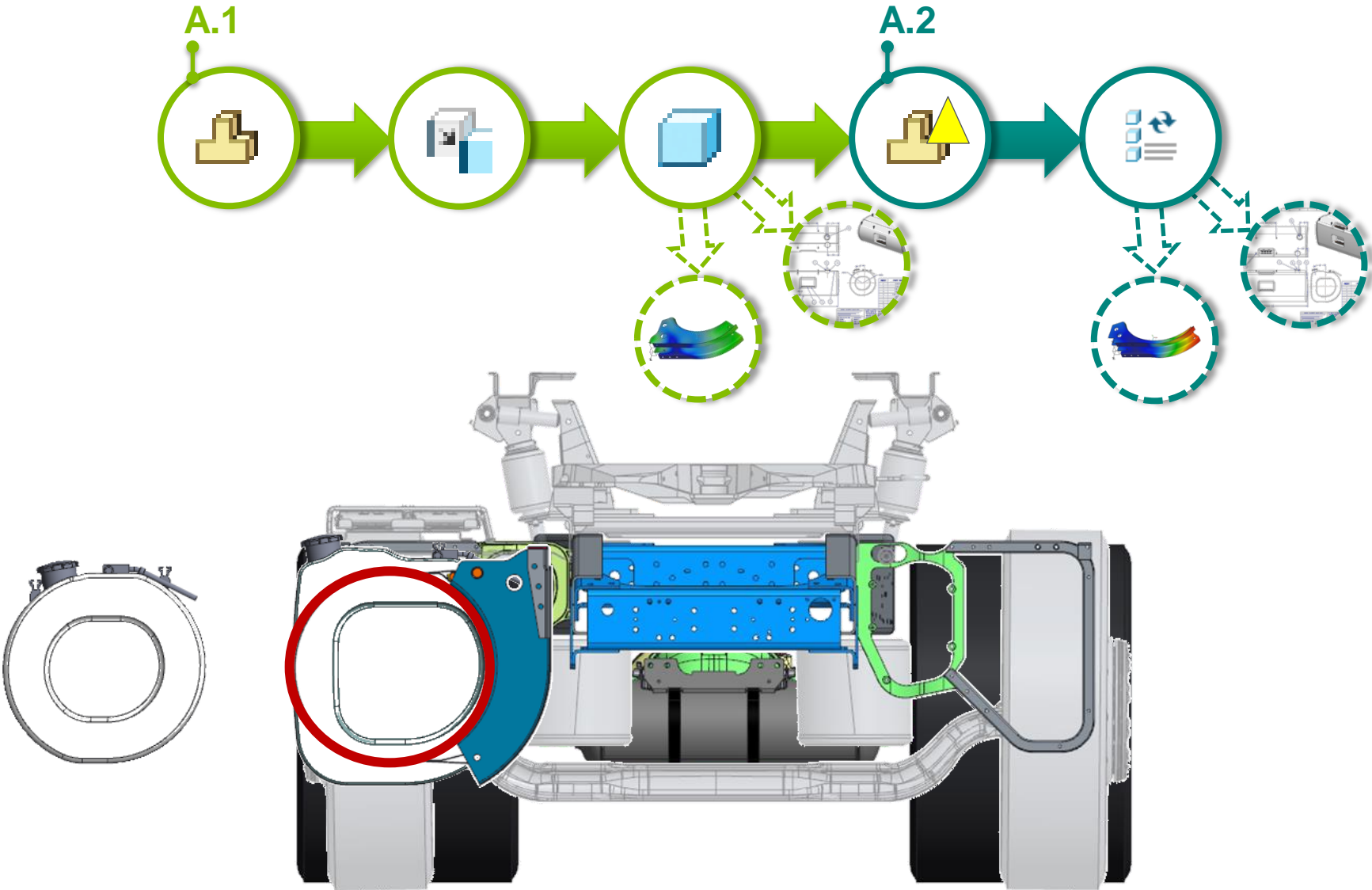

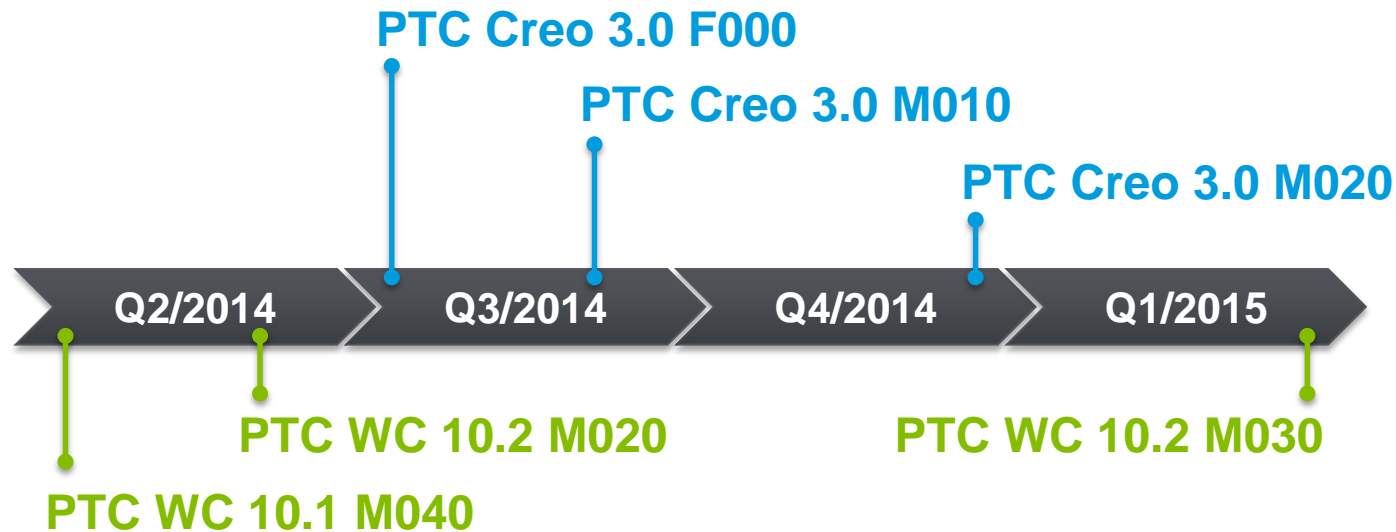

- **Availability of Unite Technology:**

- PTC Creo 3.0 F000:
 - SolidWorks, CATIA, NX & Inventor Import
 - SolidWorks, CATIA & NX Update and Save As
- PTC Creo 3.0 M010:
 - SolidEdge Import
- PTC Creo 3.0 M020:
 - Simplified Open, Update and Convert on-demand workflows for SolidWorks, CATIA & NX

- **PTC Windchill compatibility:**

- Unite Technology available with PTC Creo 3.0 F000 and M010 will be compatible with
 - PTC Windchill 10.1 M040 and
 - PTC Windchill 10.2 M020
- Simplified Open, Update & Convert on-demand workflows available in PTC Creo 3.0 M020 will be compatible with
 - PTC Windchill 10.2 M030

Enabling Optimal Multi-CAD Collaboration and Consolidation

- **Summary:**

- No need for any non-PTC license or software to be installed on a PTC Creo 3.0 workstation anymore
- Efficiently open in and convert on-demand key non-PTC Creo formats to PTC Creo 3.0 with simplified workflows
- Design in Context of Multi-CAD assemblies with confidence
- Create and maintain design intent across 3D CAD formats
- Easily share Multi-CAD data in key 3D CAD formats

- **Benefits:**

- Increase Engineering Productivity and IT Efficiency
- Easily incorporate most common 3D CAD formats early in the design process
- Reduce the impact of late stage design changes



Breakthrough Multi-CAD Technology



Concept Design Improvements



PTC Creo Efficiency Improvements

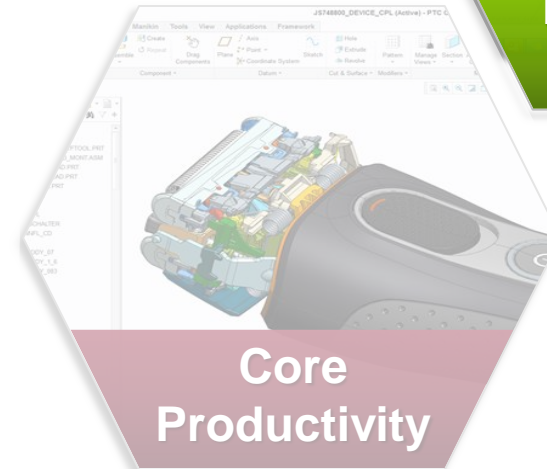

Flexibility with Control...

- **Freestyle**
Blends Freeform Design with Parametric Control
- **PTC Creo Layout**
for Conceptual Engineering
- **PTC Creo Direct**
for Concept Design
- **NEW!**
PTC Creo Design Exploration Extension

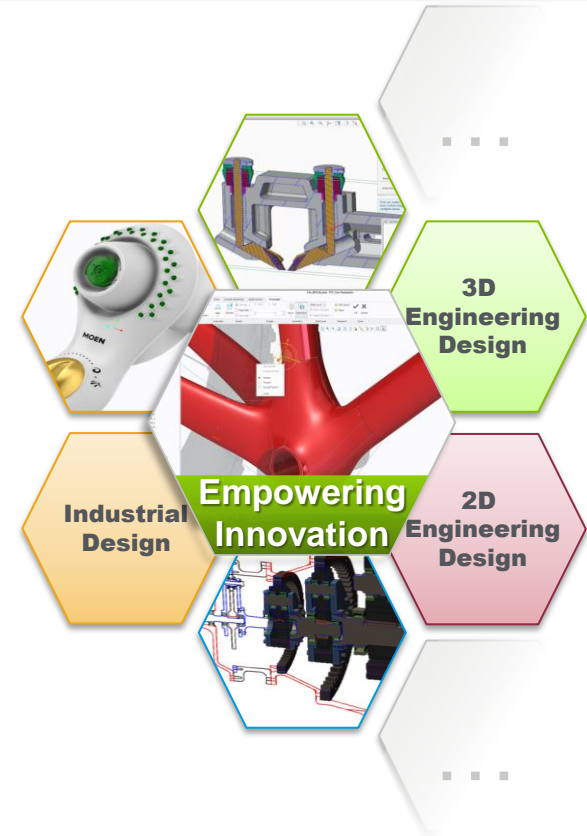

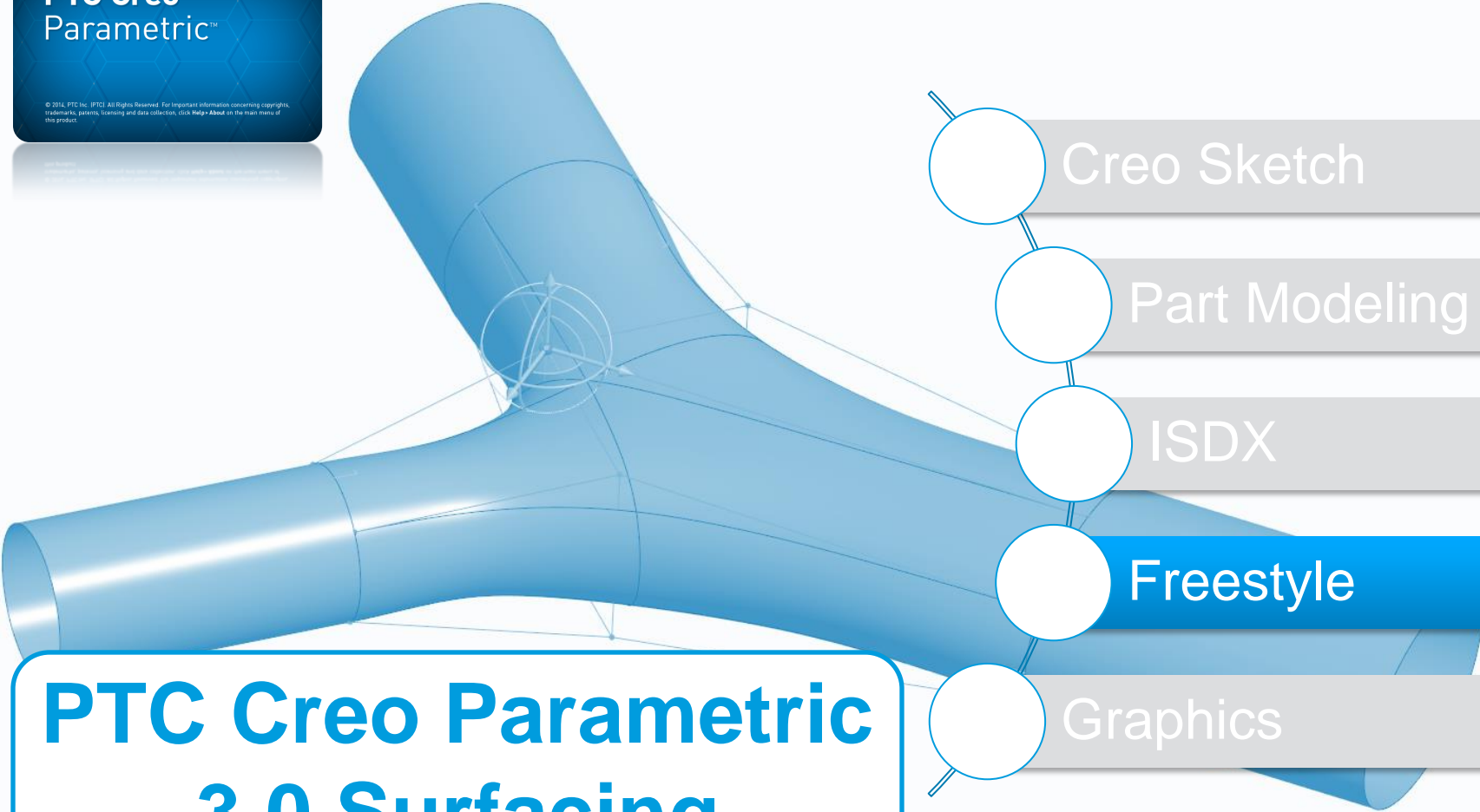

- Creo Sketch
- Part Modeling
- ISDX
- Freestyle**
- Graphics

PTC Creo Parametric 3.0 Surfacing

New Join command

Capabilities

- Ability to Join faces and edges
- Support for Join Mirror
- Dependent on selection order
 - Second selected entity moves to first
- Available in RMB menu

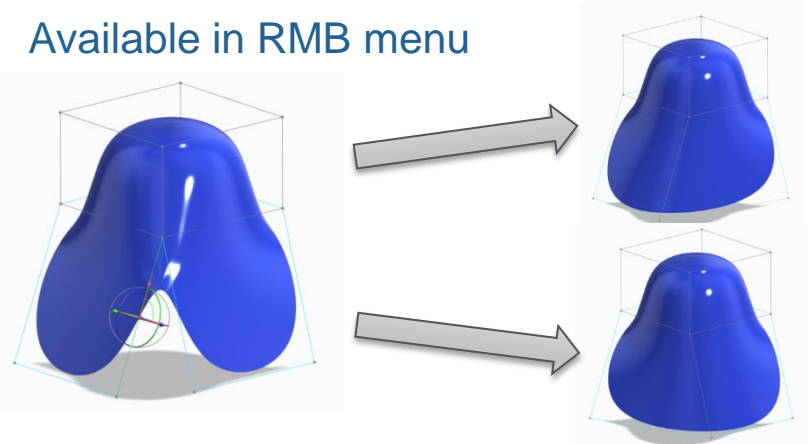

Benefits

- Increased speed for changing control mesh topology

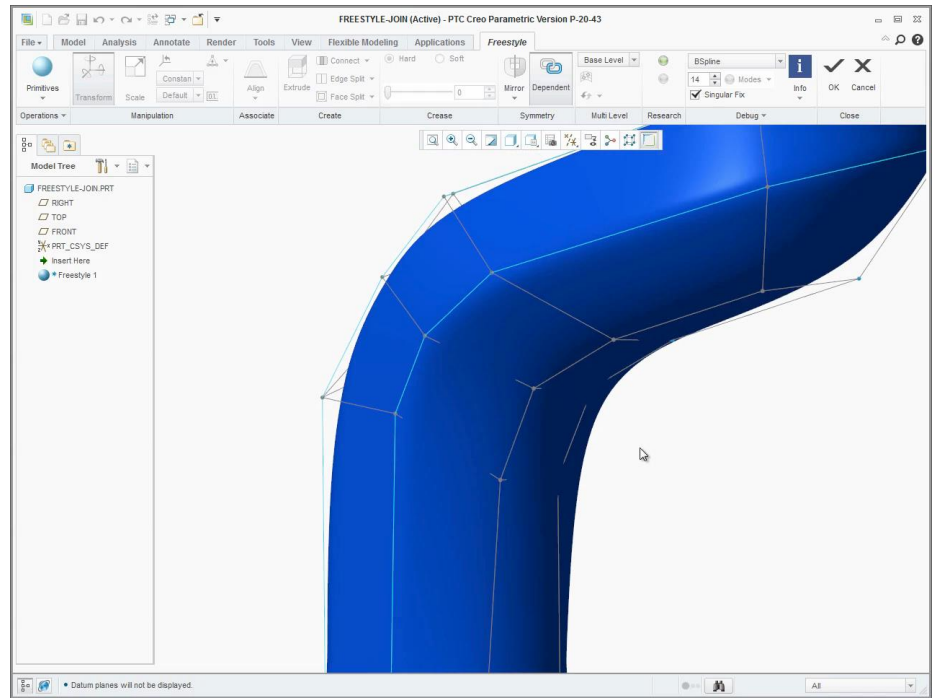
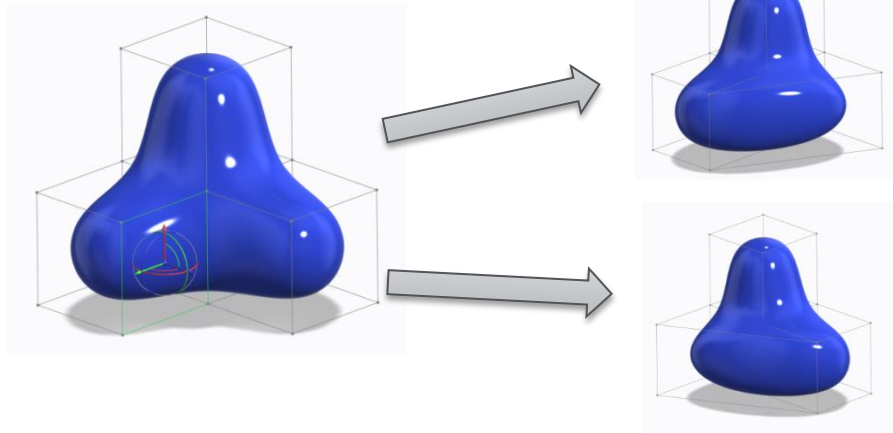

New Align to external geometry

Capabilities

- Align to external curves or edges
- Support for connects
 - Position, Normal & Tangent
- Control over alignment limit handles
- Support for:
 - 1 and 2 sided edges with or without creases
 - Mirror
- **NOTE:** Selected curves/edges must be G2

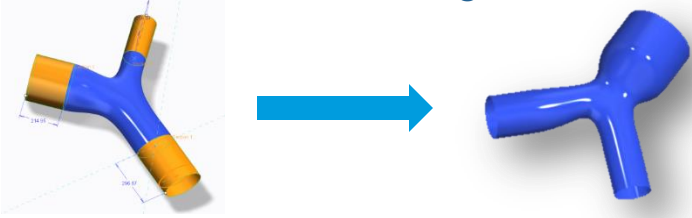

Benefits

- Add parametric design intent to Freestyle geometry
- Improved productivity

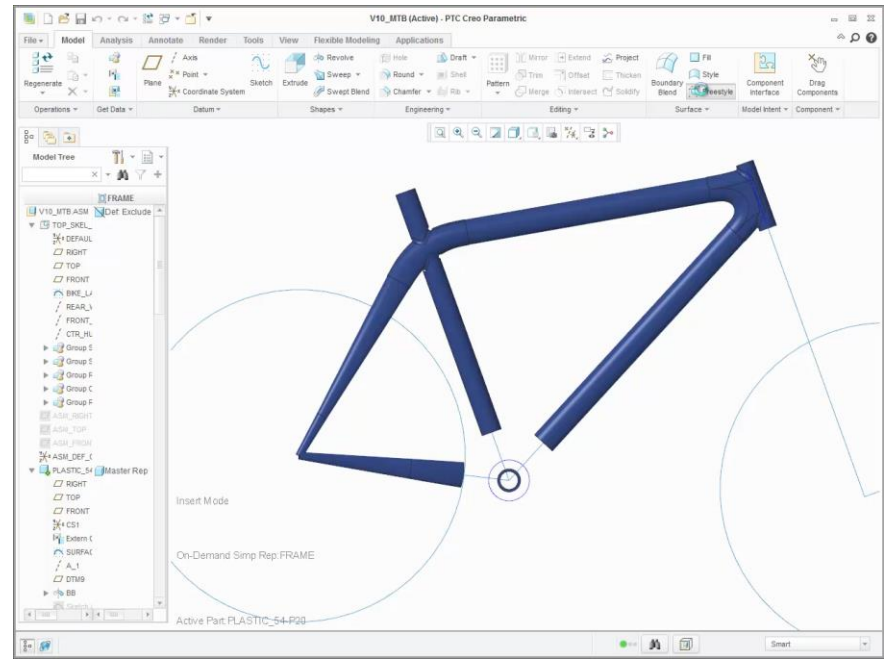

Manipulation Performance

Capabilities

- Faster manipulation of control mesh
 - Display quality and geometry reduction during drag operations
 - Available as an option (on by defaults)

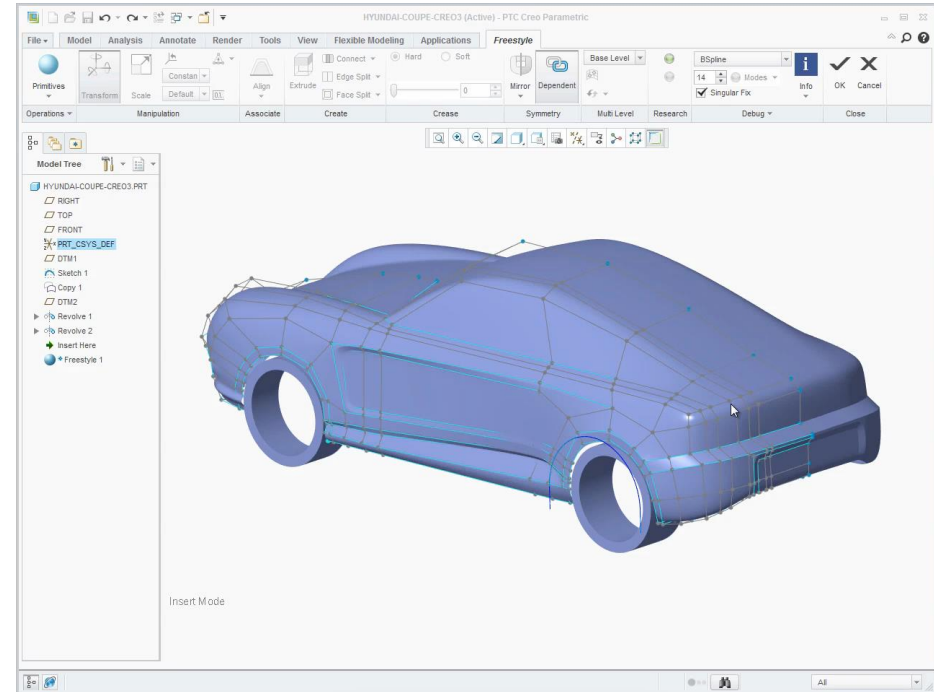

Benefits

- Improved productivity

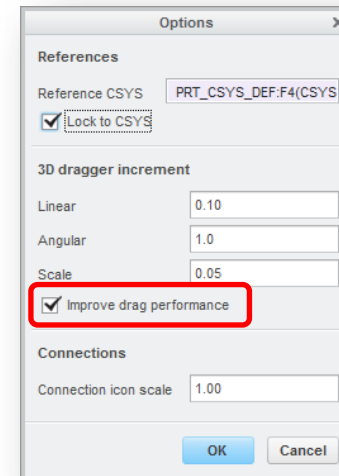

Flexibility with Control...

- **Freestyle**
Blends Freeform Design with Parametric Control
- **PTC Creo Layout**
for Conceptual Engineering
- **PTC Creo Direct**
for Concept Design
- **NEW!**
PTC Creo Design Exploration Extension

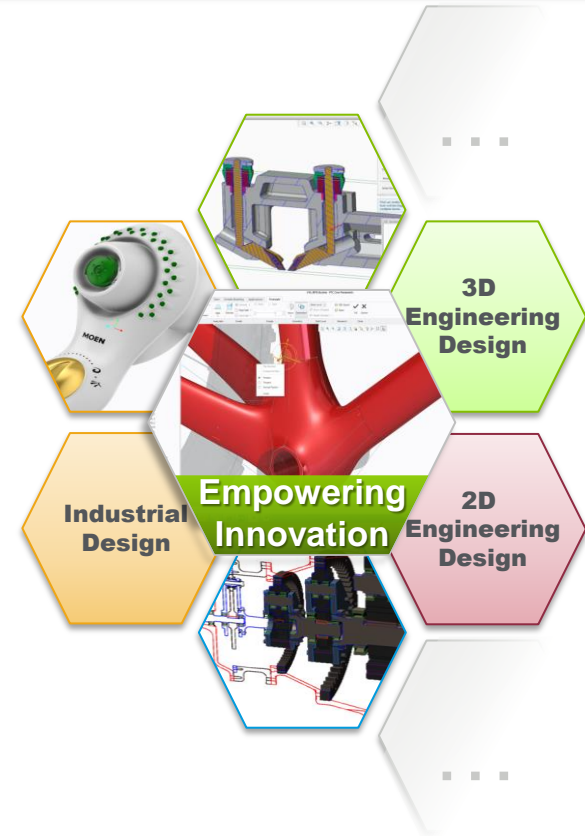

2D Design Capabilities

PTC Creo Layout

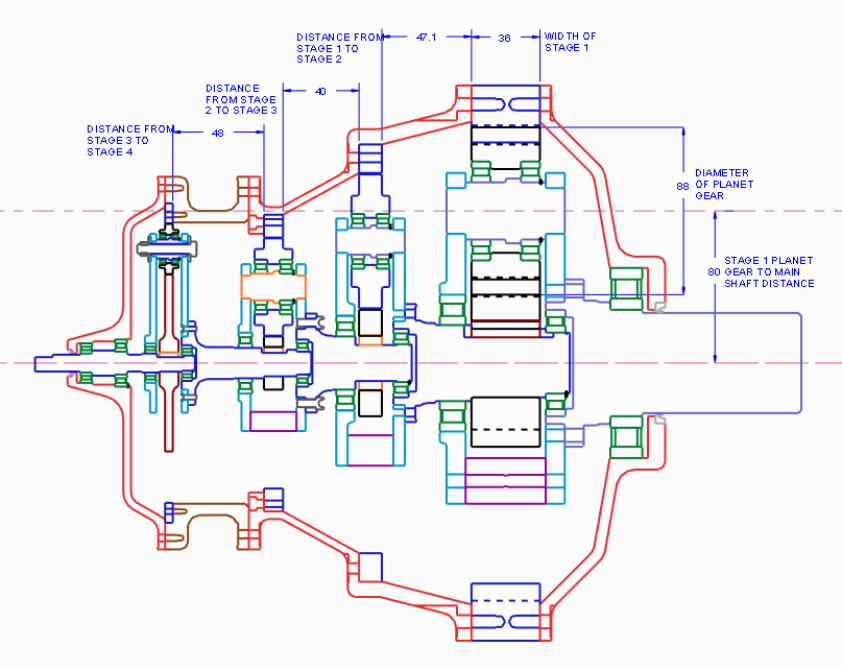

3D Integration Capabilities

PTC Creo Parametric

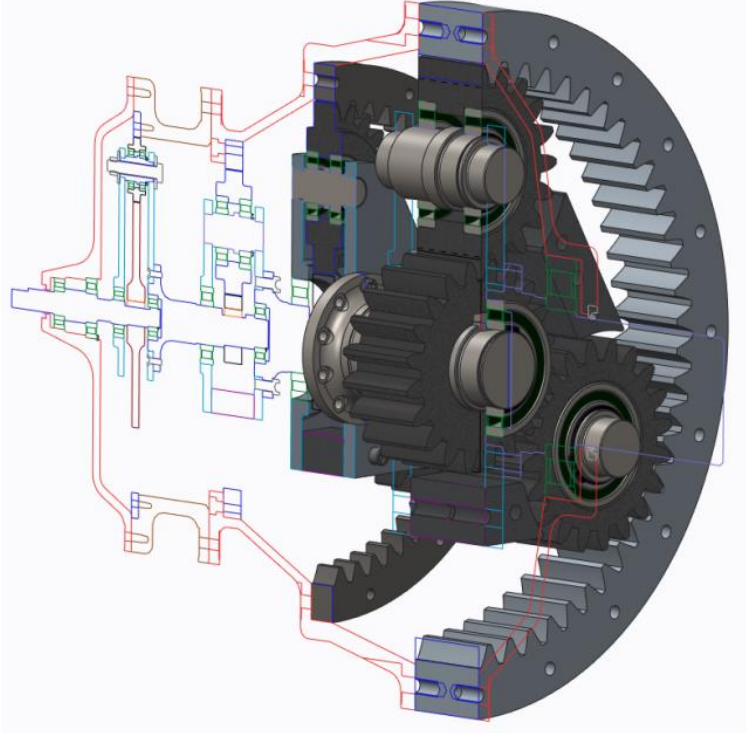

2D Design Capabilities

PTC Creo Layout

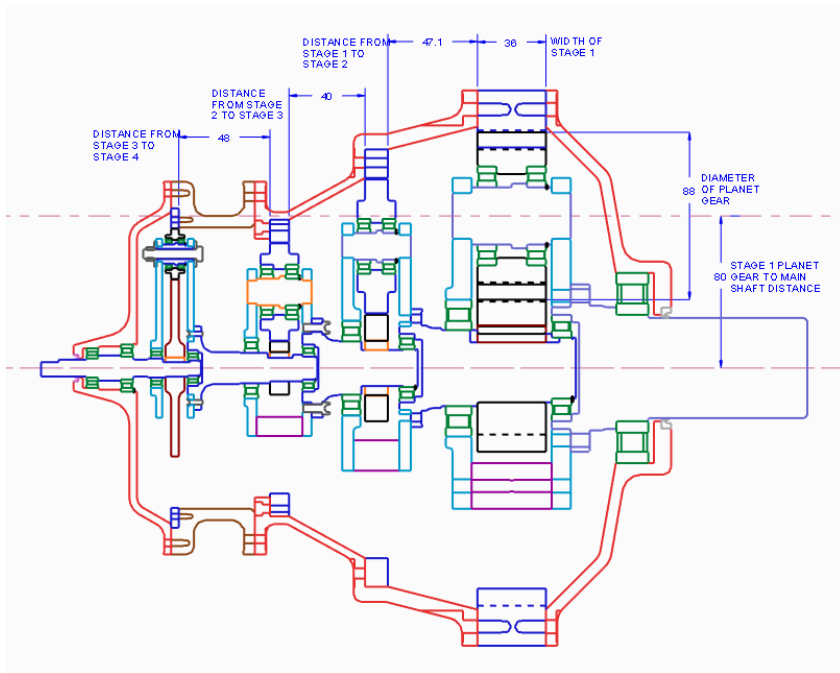

3D Integration Capabilities

PTC Creo Parametric

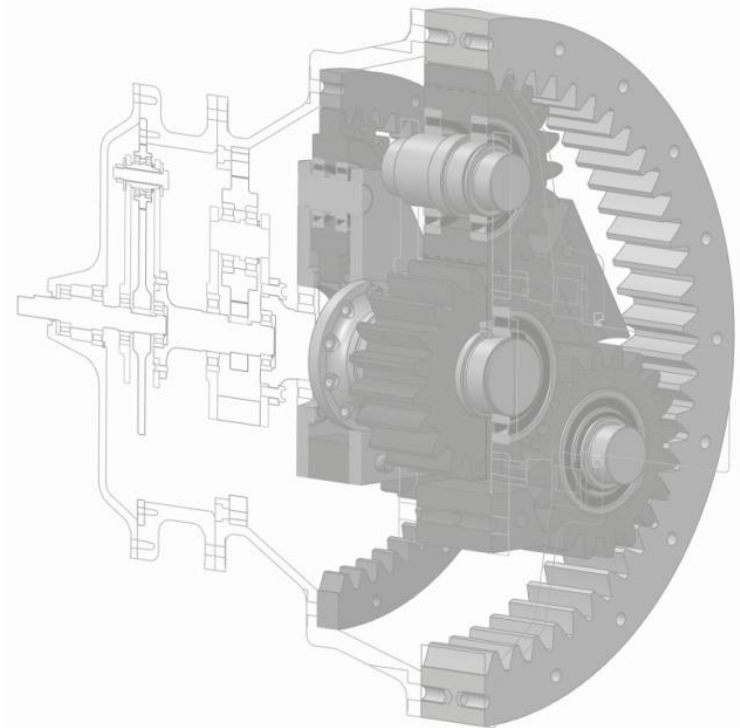

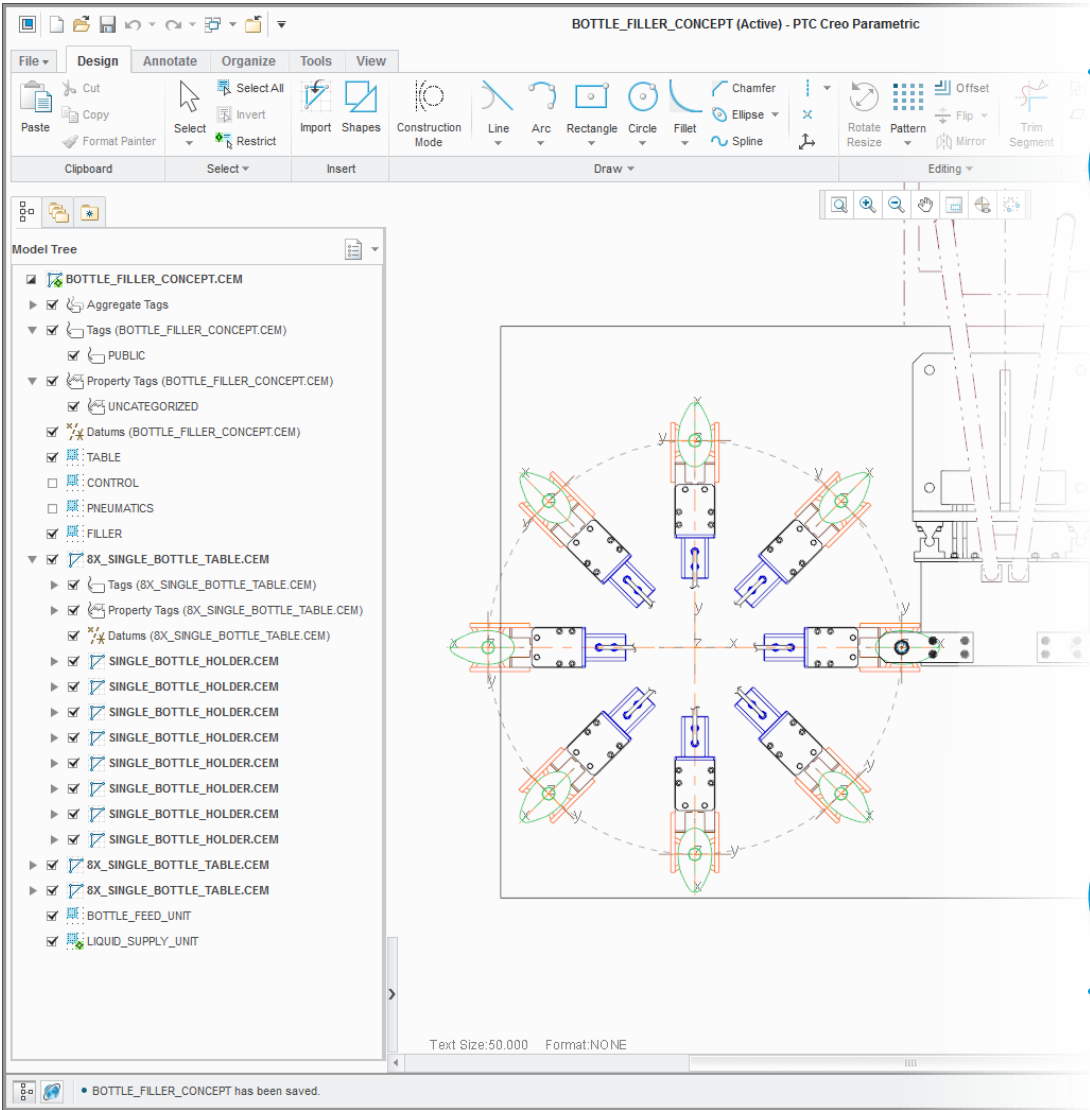

Data Importing



2D Sketching



Data Organization



Detailing



Geometry Editing

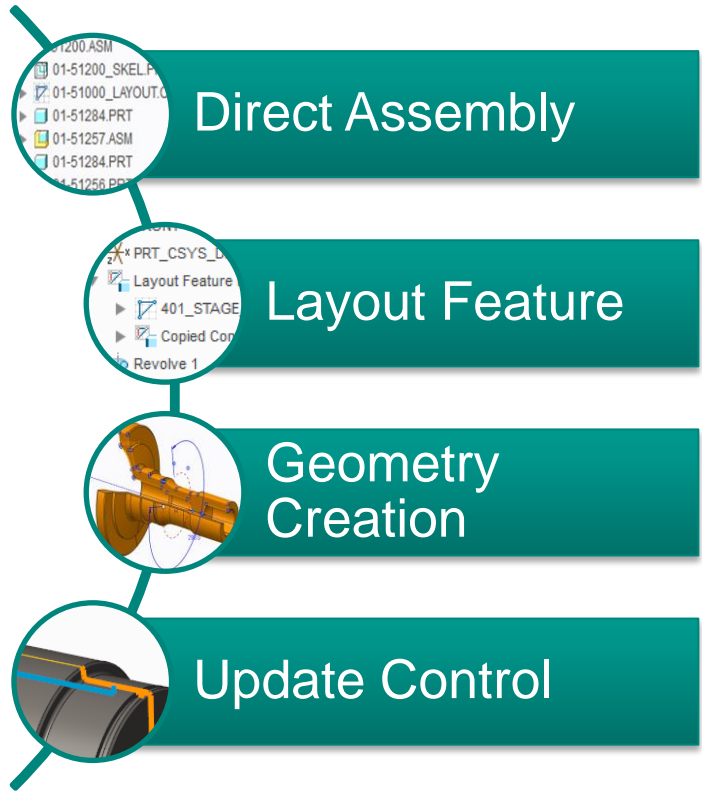
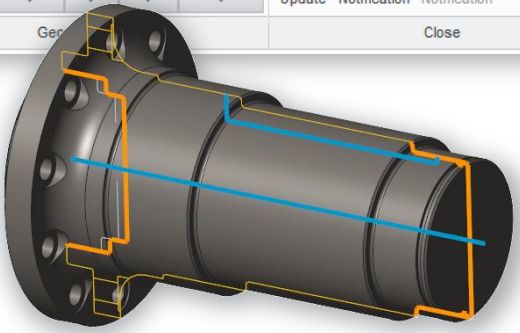
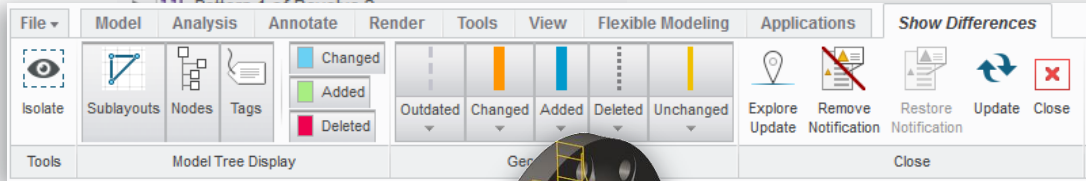
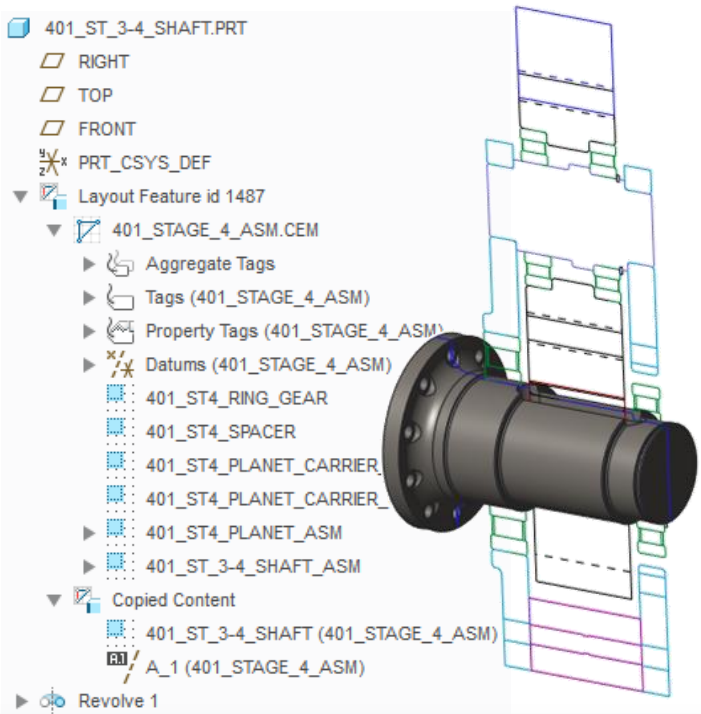

Improved Scalability, Collaboration and 3D Integration

- PTC Creo Layout for 2D Conceptual Engineering

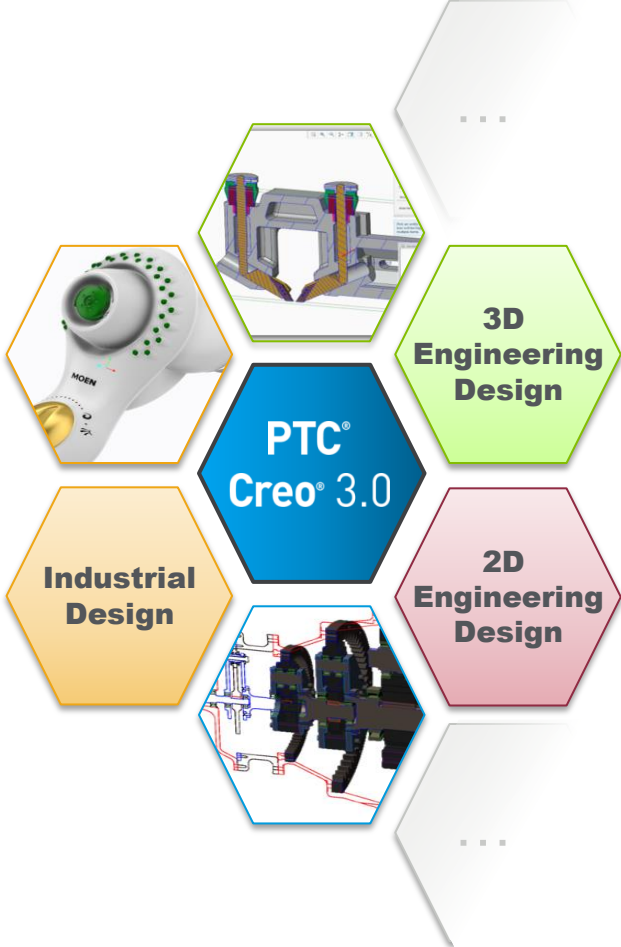
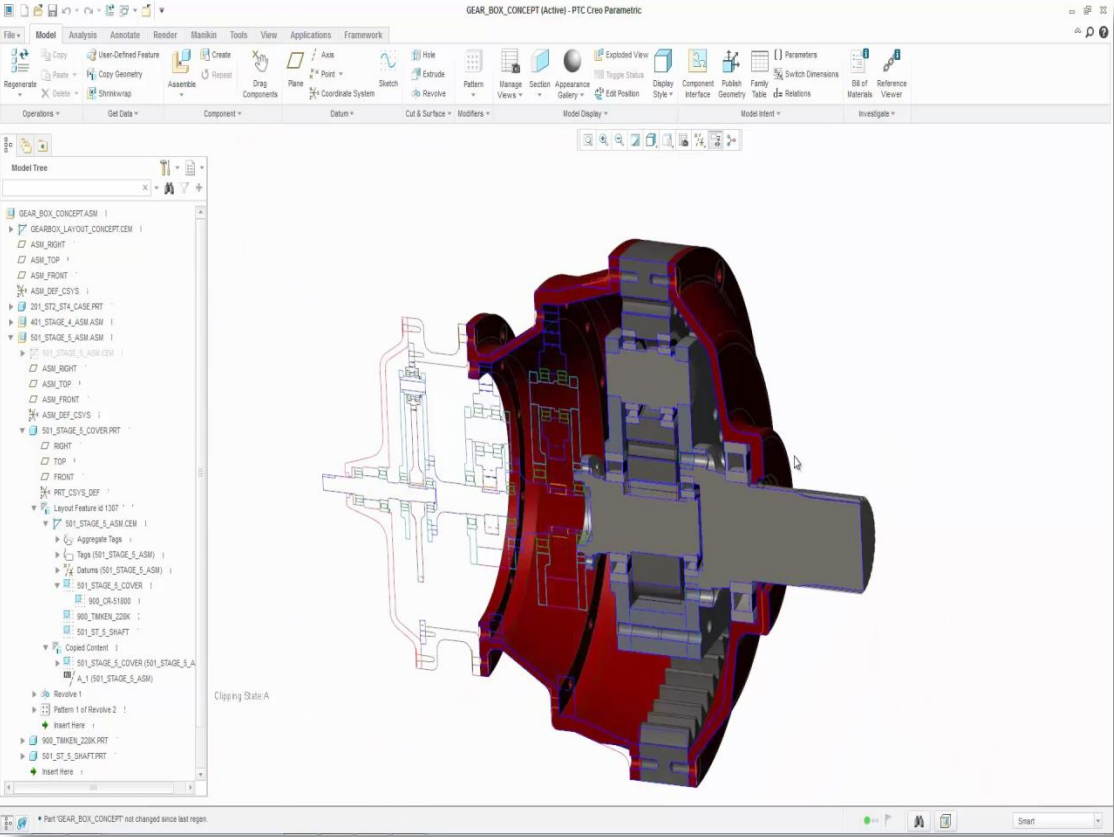

Flexibility with Control...

- **Freestyle**
Blends Freeform Design with Parametric Control
- **PTC Creo Layout**
for Conceptual Engineering
- **PTC Creo Direct**
for Concept Design
- **NEW!**
PTC Creo Design Exploration Extension

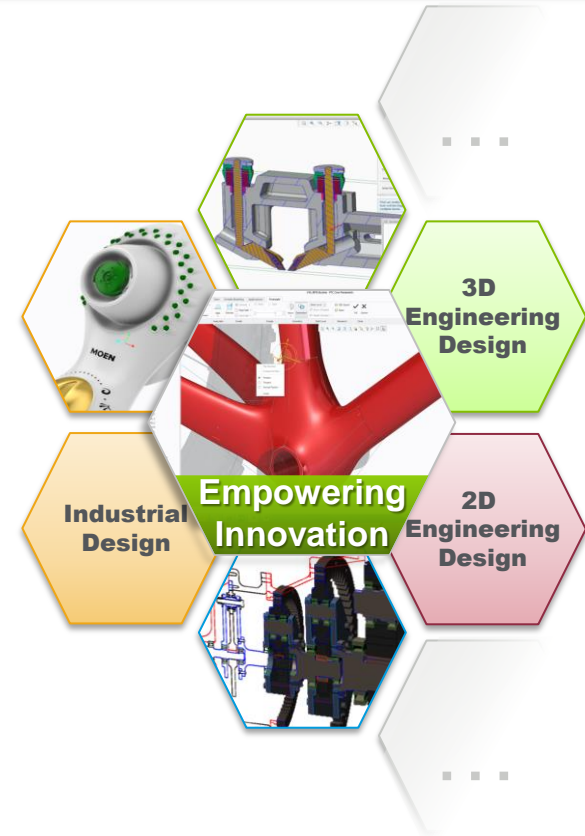

a **scalable, interoperable** suite of product design software that delivers **fast time to value**

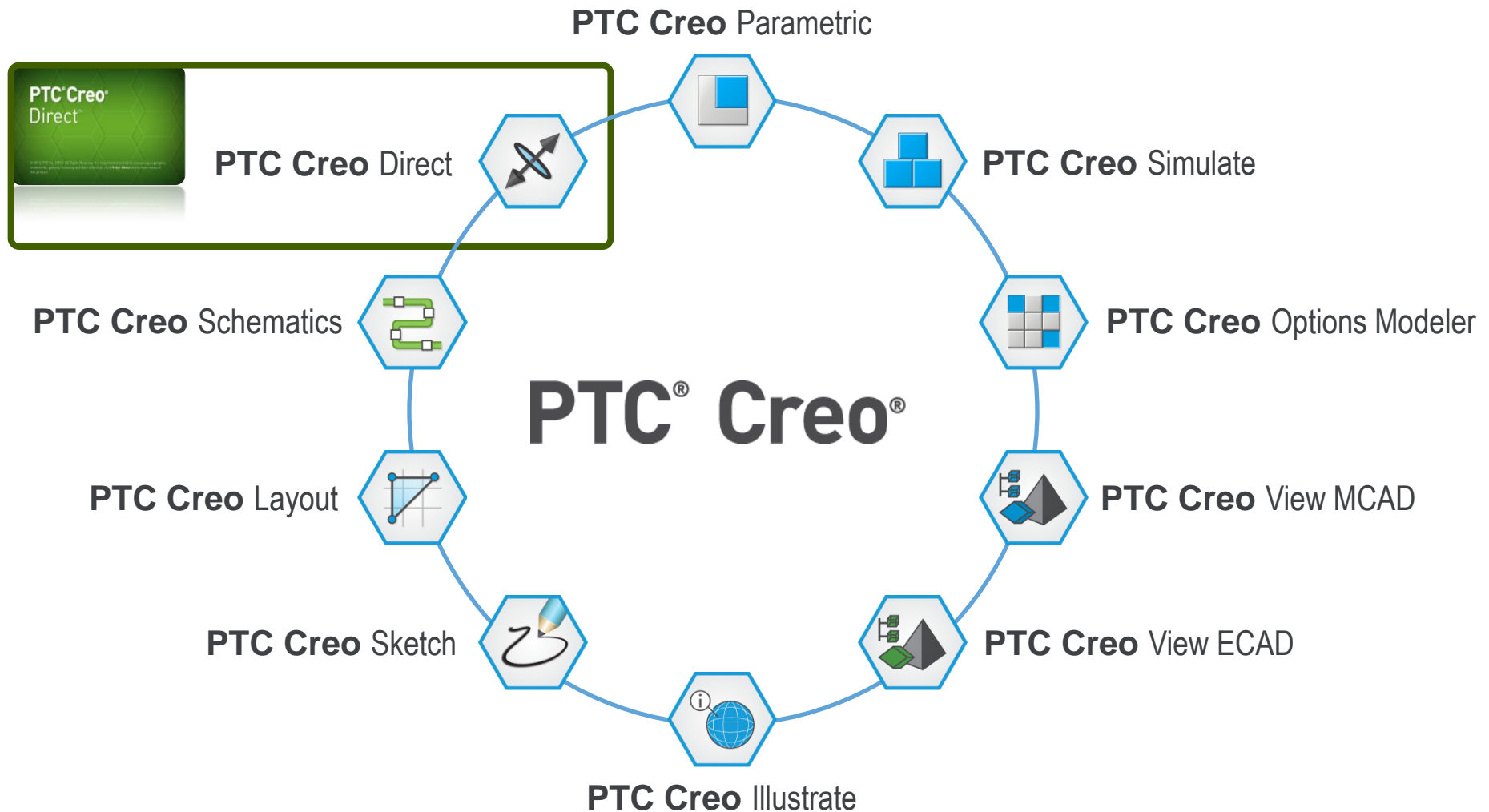

Quickly Creating 3D Concepts

- **Capabilities**

- Fast, flexible 3D geometry creation and editing designed for occasional users
- Move, attach and remove geometry
- Create and move components in an assembly context
- Quickly position components with on-the-fly constraints
- Change Tracking with PTC Creo Parametric
- Import non PTC Creo data

- **Benefits**

- Enables cross-functional users to make design edits and suggestions
- Easy, fast support for bid proposals
- Faster, more flexible concept and detailed design

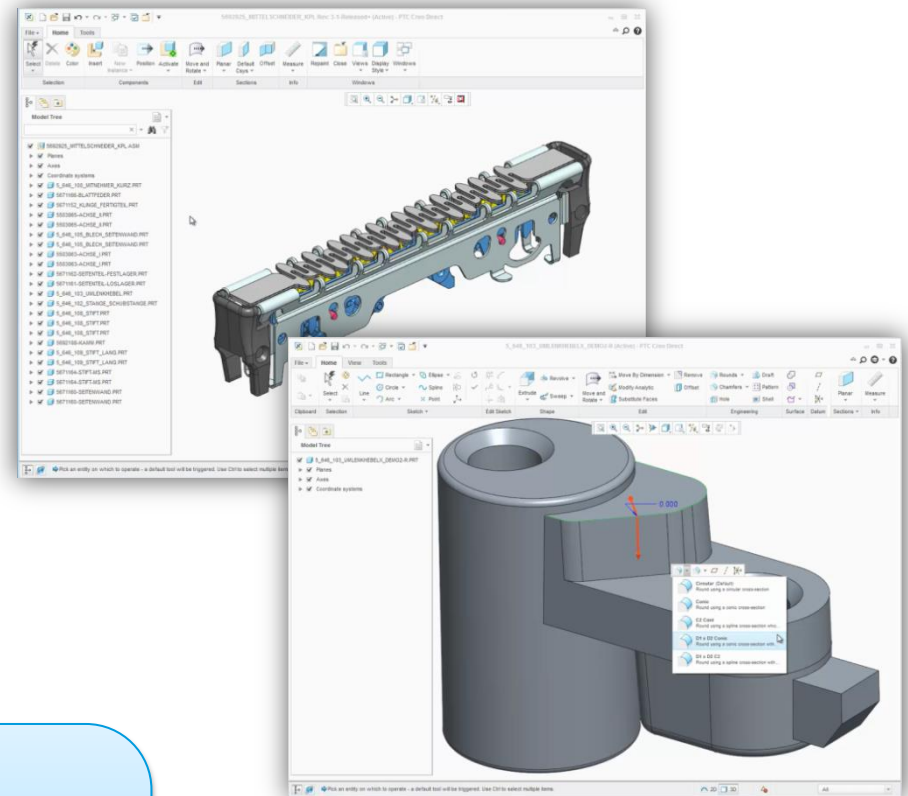

Allow occasional users to make easy, intuitive changes to existing models

Flexibility with Control...

- **Freestyle**
Blends Freeform Design with Parametric Control
- **PTC Creo Layout**
for Conceptual Engineering
- **PTC Creo Direct**
for Concept Design
- **NEW!**
PTC Creo Design Exploration Extension

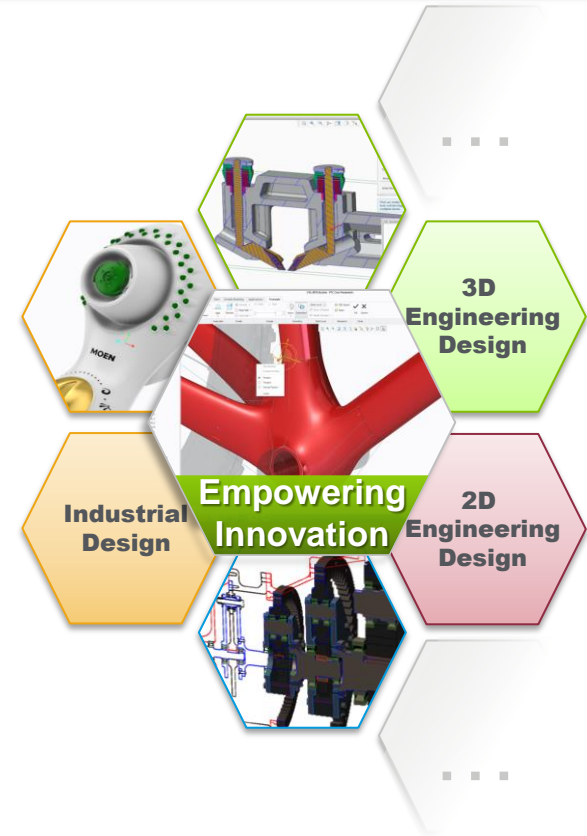



- About to pe
- Evaluate diff
- Incorporate new ideas into th

Typically these involve...

- **Back-up** and **duplicate** models to ad-hoc folders... Multiple times
- Repeatedly closing/clearing session to **reload different design versions**
- Take a lot of **screenshots** to use for Design Review...
- **Manually identify**/incorporate design changes to **carry forward** for “real”

- Split to different directions
- Develop simultaneously different ideas
- Evaluate all options before making decisions



- Can initiate with already modified items
 - Start models captured: Pre-modified
 - Modified models: Entry checkpoint
- **One-way download** when in active Design Exploration session
 - Can only upload “legit” designs from regular session
- Store TMZ file
 - Design Review
 - Documentation
 - Revisit decisions
 - ...

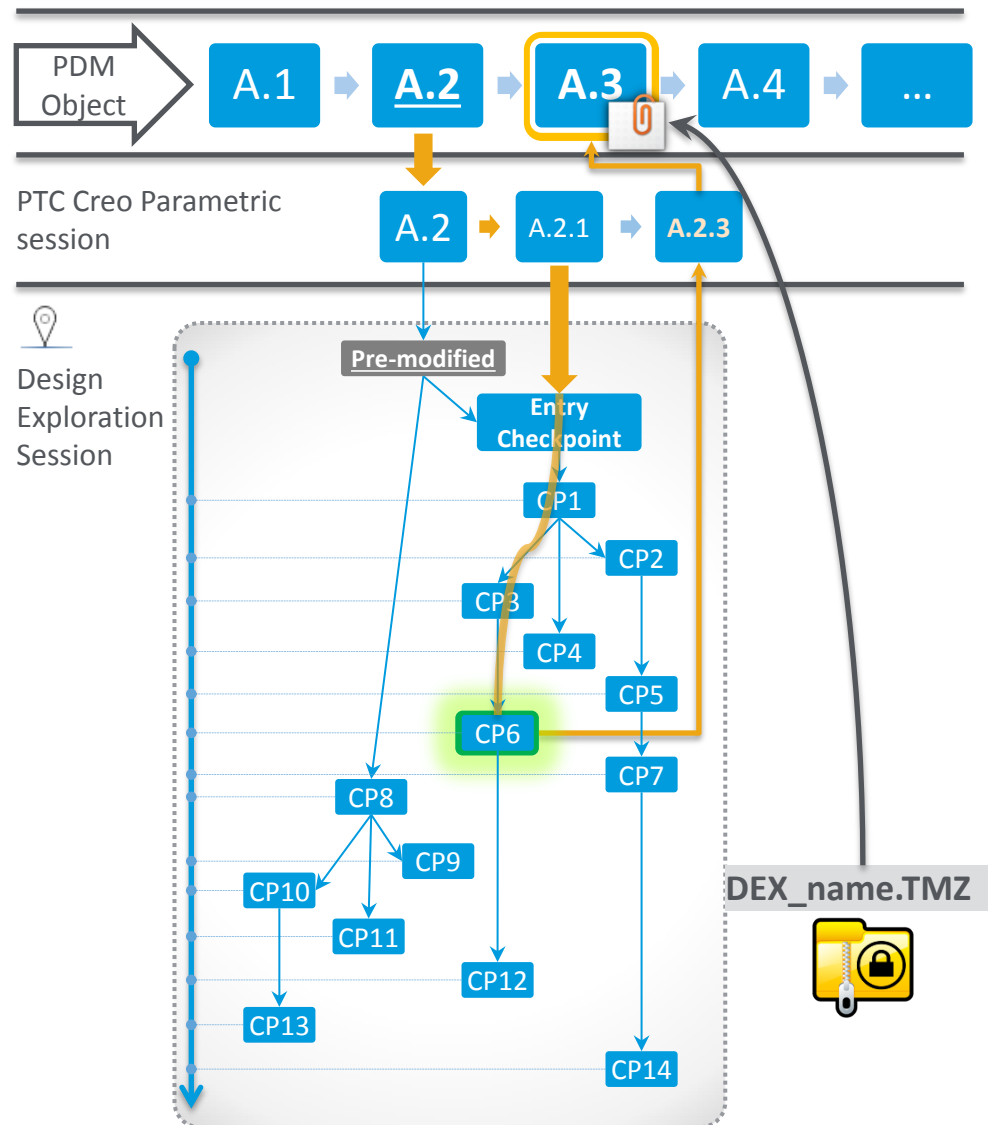

- Entity level changes tracking
- Selective children update
 - Propagate to all children in one shot
 - or update only some

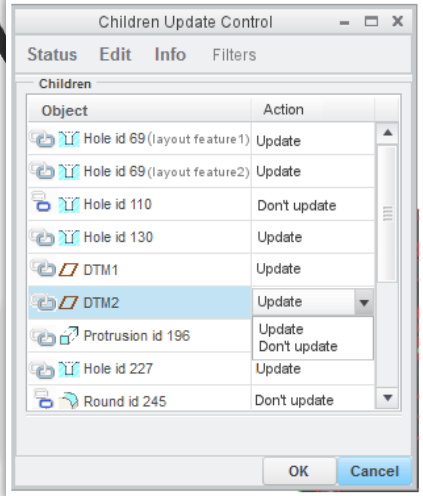
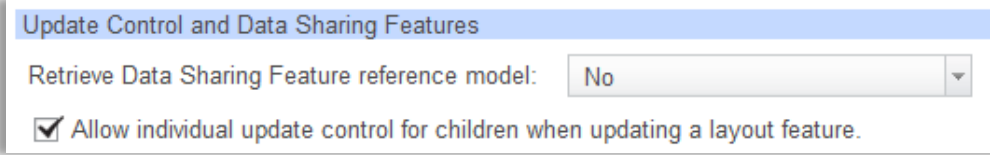
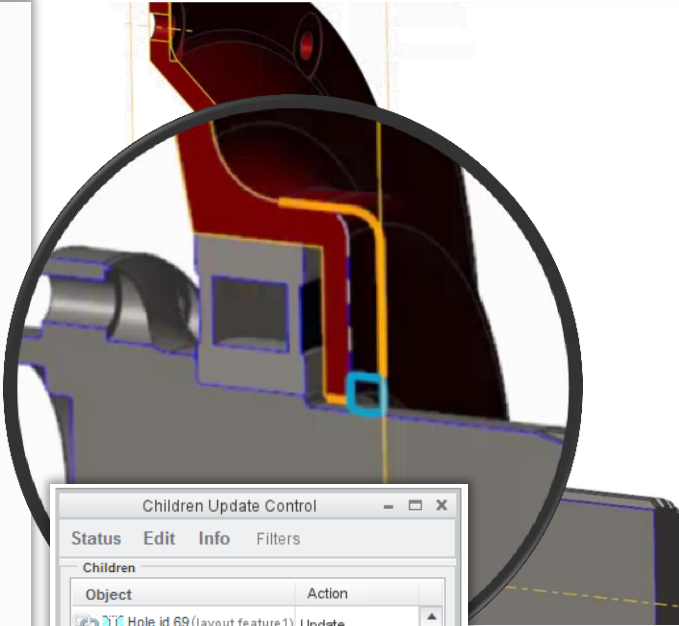
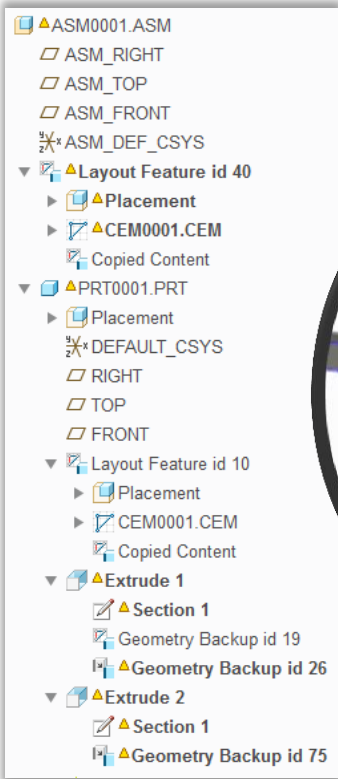
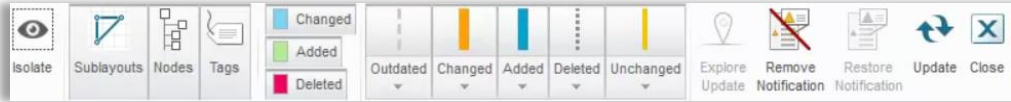

Flexibility with Control...

- **Freestyle**
Blends Freeform Design with Parametric Control
- **PTC Creo Layout**
for Conceptual Engineering
- **PTC Creo Direct**
for Concept Design
- **NEW!**
PTC Creo Design Exploration Extension

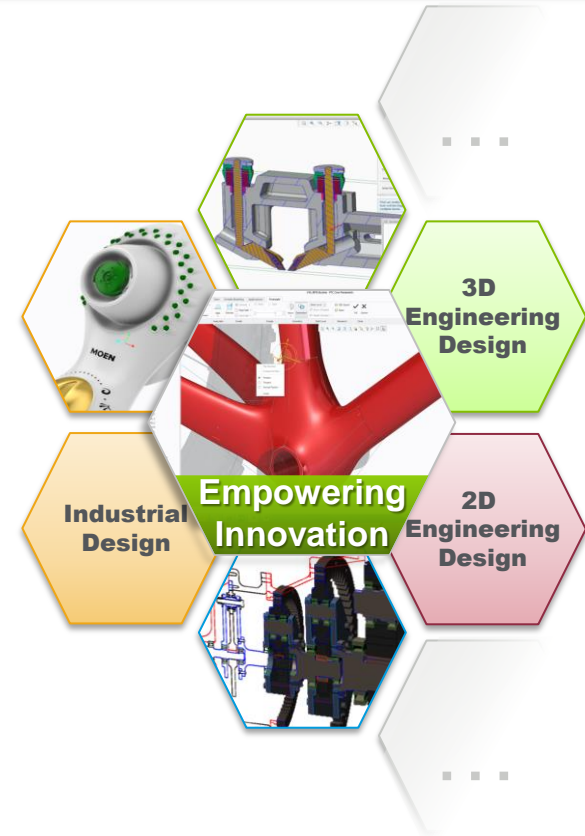

Breakthrough Multi-CAD Technology



**Unite
Technology**

Concept Design Improvements



**Empowering
Innovation**

PTC Creo Efficiency Improvements



**Core
Productivity**

Leg Stretch – 5 min Break





General



Part Modeling

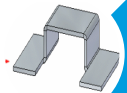

Sheet-Metal



Flexible Modeling



Surfacing



Graphics



Assembly



Mold

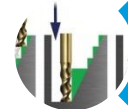

NC



Routed Systems

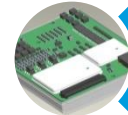

ECAD



Harness Mfg

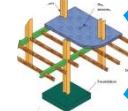

Advanced Framework

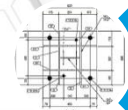

2D & 3D Detailing

Overview

- **Adoption Aids**
 - New getting started
 - New help system
- **Expansion of Library suppliers**
 - COTS
 - Intelligent Fastener Extension
- **App compliance**
 - Automatic window activation
 - RMB commands
 - No Version extension option



New Getting Started Experience

- Revamped Help, Google indexed and searchable on the web
- Startup Tutorials shipped with the product
- Additional tutorials downloaded through Learning Exchange
- 80+ What's New Videos available on Learning Exchange



Family tables

What's New: PTC Creo Parametric 3.0
Fundamentals

- Fundamentals
 - Fundamentals Overview
 - Configuring Fundamentals
 - User Interface Basics
 - Creo Parametric User Interface
 - Working with the Model
 - Annotation Features
 - Driving Dimension Annotation Elements
 - Creating Various Annotation Types
 - Working with Model Properties
 - Relations and Parameters
 - Family Tables
 - Basics of Family Tables
 - Creating Family Tables
 - Adding Items to Family Tables
 - Creating Instances of Parts or Assemblies in Family Tables
 - Working with Instances in Family Tables
 - Retrieving Instances
 - Searching in a Family Table
 - Saving Family Table Information
 - Working with Family Tables
 - Glossary
 - Collaboration Tools
 - Program

Help Resources

Free Tutorials
PTC Creo Community
Customer Support
Contact PTC

Fundamentals > Fundamentals > Family Tables > Basics of Family Tables > About Family Tables

About Family Tables

Family Tables are collections of parts (or assemblies or features) that are essentially similar, but deviate slightly in one or two aspects, such as size or detail features.

For example, wood screws come in various sizes, but they all look alike and perform the same function. Thus, it is useful to think of them as a family of parts. Parts in Family Tables are also known as table-driven parts.

The following figure shows a family of bolts. The generic is at the top of the figure, and its instances are underneath. The generic is the parent.

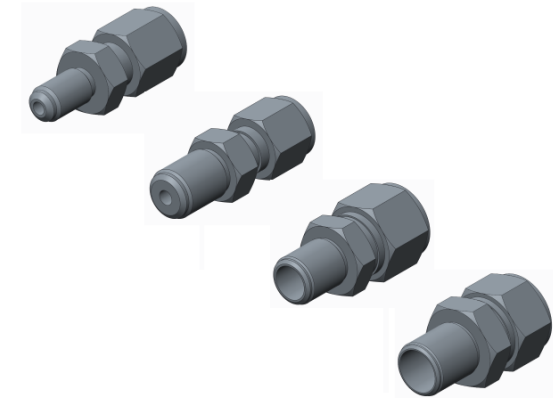

Using Family Tables, you can:

- Create and store large numbers of objects simply and compactly
- Save time and effort by standardizing part generation
- Generate variations of a part from one part file without having to re-create and generate each one
- Create slight variations in parts without having to use relations to change the model
- Create a table of parts that can be saved to a print file and included in part catalogs

Family Tables promote the use of standardized components. They let you represent your actual part inventory in PTC Creo Parametric. Moreover, families make it easy to interchange parts and subassemblies in an assembly, because instances from the same family are automatically interchangeable with each other.

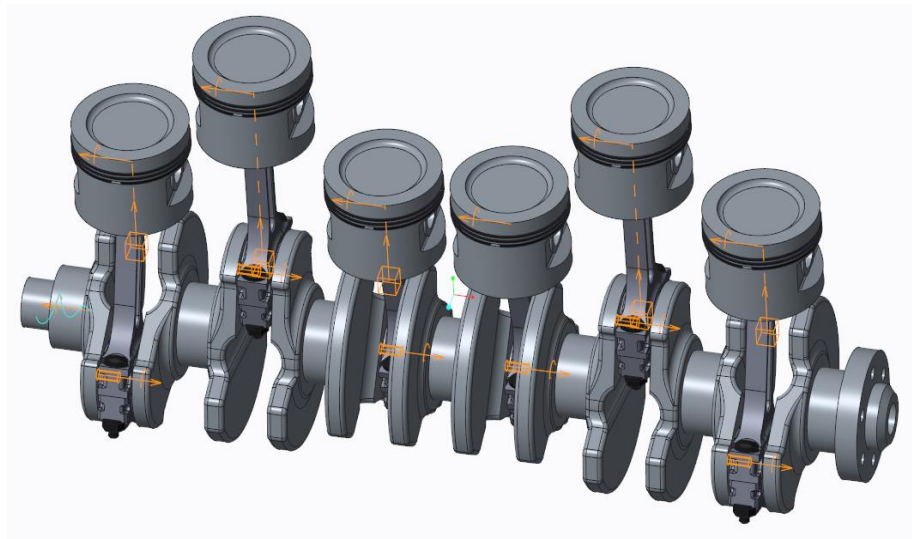

Expansion of Library Supplier

- **Catalog Data Solutions**
 - New “Google” type approach for library objects
 - US Head office
- **Cadenas**
 - Portal style library
 - Single user interface, single login
 - Localised into
 - Chinese, French, German, Italian, Japanese, Korean, Polish, Portuguese, Russian, Spanish
 - European Head office
 - Offices in USA, Japan & China

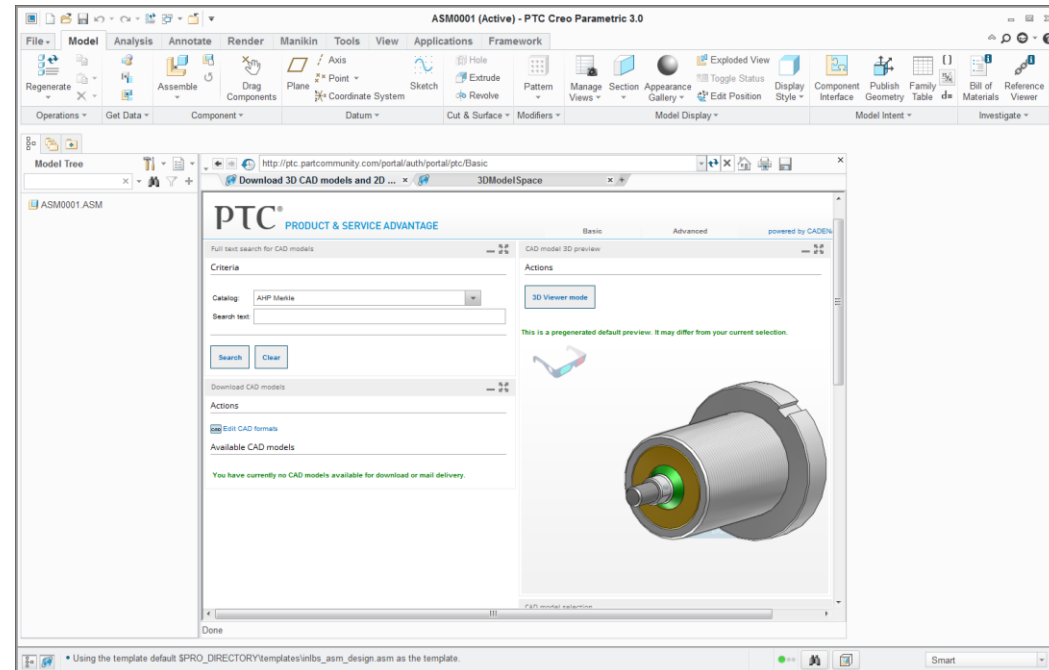

Introduction

Using traditional modelling techniques to create a hole in each part and assemble the socket head cap screw will take the average user at least 35 mouse clicks and 96 seconds.

PTC Creo Intelligent Fastener eXtension (IFX) automates the creation of holes and assembly of fasteners within a single user interface reducing the workload to 11 mouse clicks and 19 seconds.

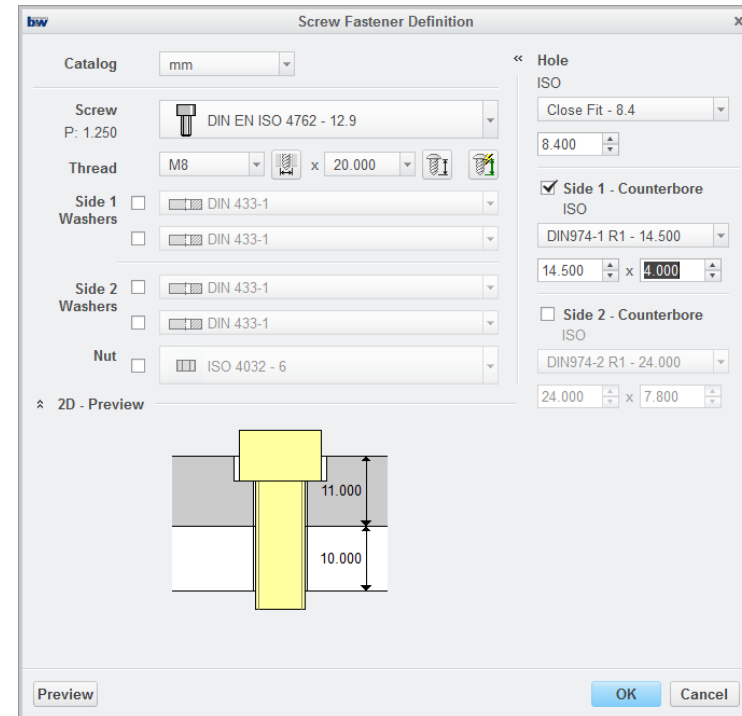
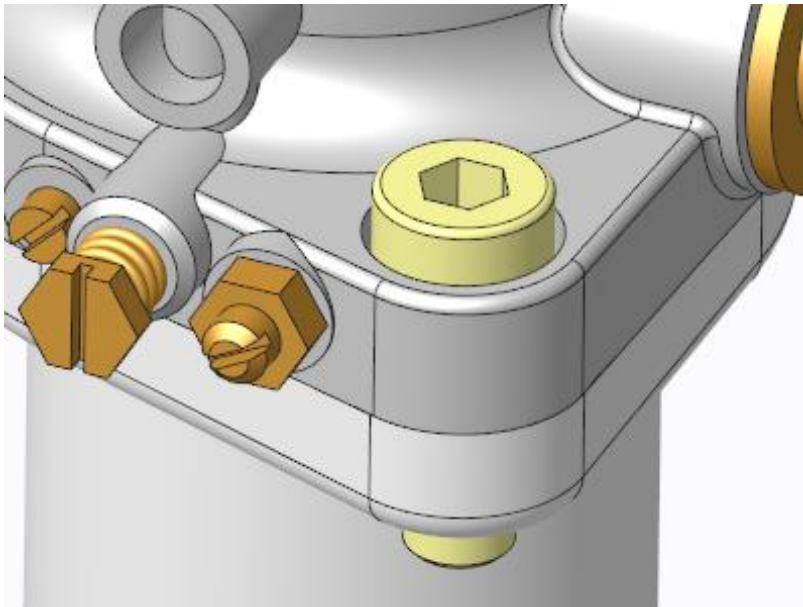

UI Improvements

Capabilities

- **Automatic Window activation**
 - No longer a need to manually activate a windows when switching
- **RMB commands**
 - Selection based RMB commands modernized
 - Customization through Options dialog to allow enabling/disabling and reordering of commands
- **No Version extension**
 - Config option to control
 - save_file_interations Yes*
 - Existing revisioned parts will remain

Benefits

- **Makes product more windows compliant**
 - More familiar to the users
- **Improved productivity**
- **Have the right commands available for your needs in the RMB**

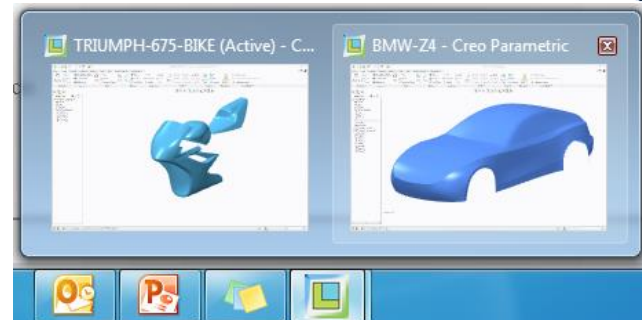
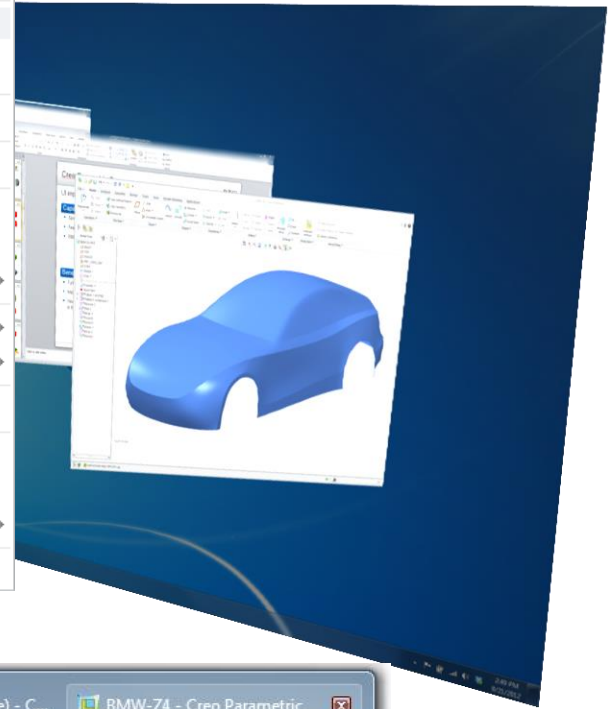
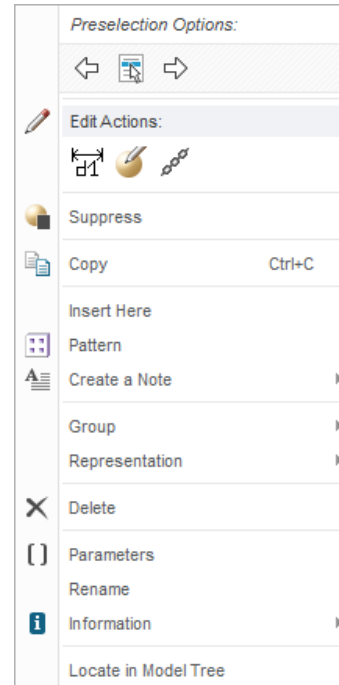

User Interface Improvements

Capabilities

- Removal of Menu Manager from feature operations
 - Feature Copy
 - Copy / Paste in Operations group and short cut keys
 - Reorder
 - New UI for dedicated to Reordering features
 - Insert Mode
 - Drag and Drop or RMB menu
- Read Only
 - New User Interface
 - Read Only features are grouped in the model tree and shown with a lock icon

Benefits

- Further removal of Menu Manager
- Improved productivity and user experience

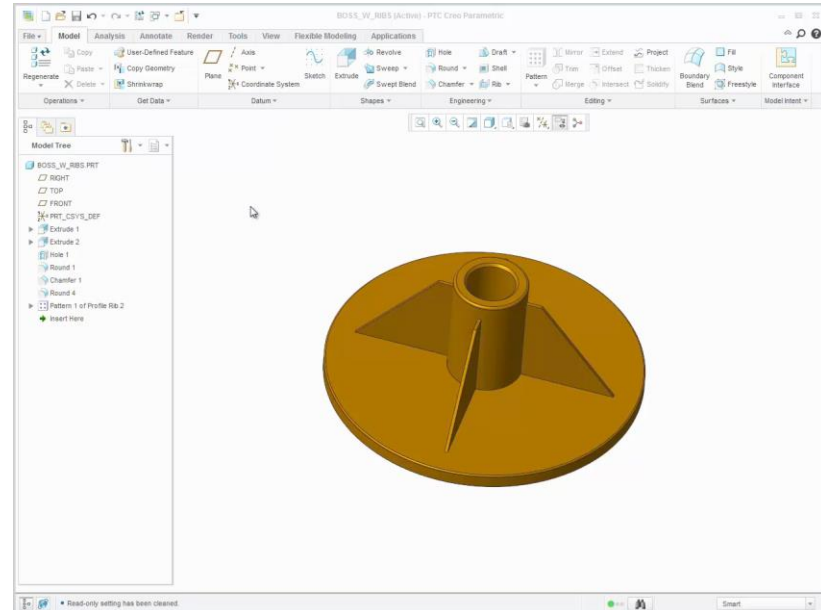
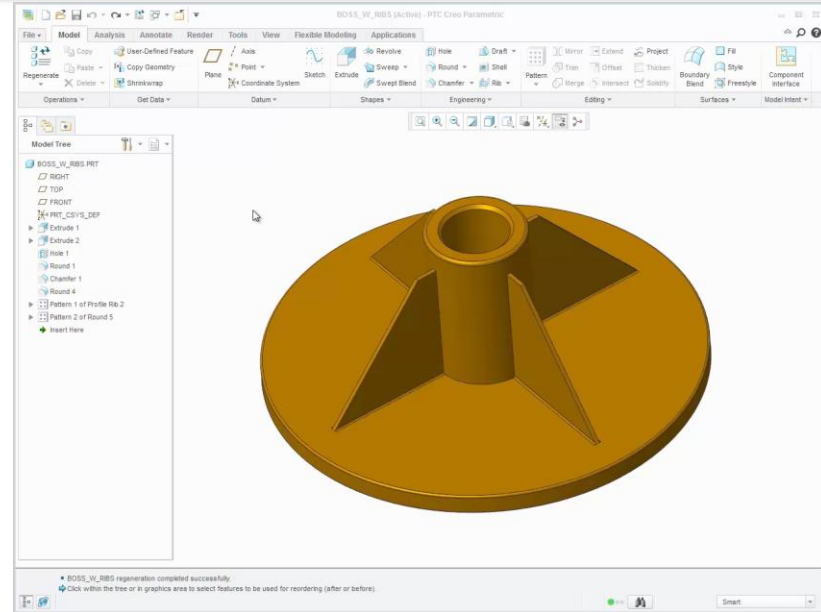

User Interface Improvements

Capabilities

- Spinal Bend
 - New dashboard UI
 - Bend entire object, blind distance, or up to reference
 - Options to maintain length, keep geometry outside the bend area
 - Easier to control standard x-section properties without relations

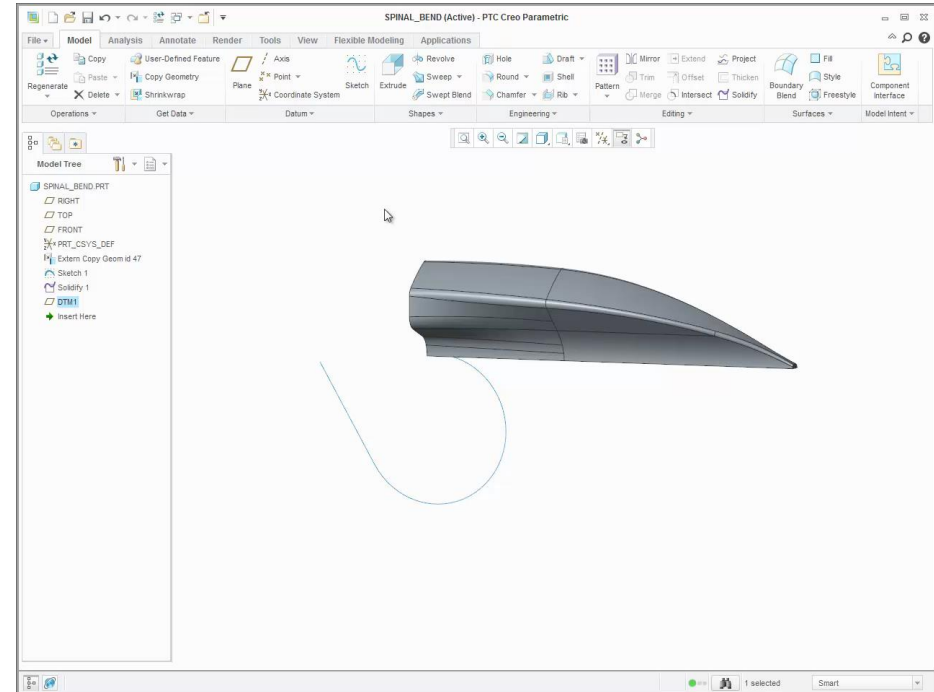

Benefits

- Further removal of Menu Manager
- Improved productivity

Reference control

Capabilities

- **New edit referenced UI**
 - Reroute feature and have ability to reroute other features with same references
 - Option to step through multiple solutions
 - Replace a Reference used in any or all features
- **Display missing references**
 - Display the last successful regeneration of a reference
 - During Edit References, Replace References, Edit Definition, Reference Viewer and Troubleshooter
- **UDF placement**
 - Auto advance and redefine feature enhancement
- **Paste Special**
 - Auto Advance for references

Benefits

- Faster, more powerful and intuitive reroute
- Similar UI for Edit and Replace References
- Easily identify missing reference location

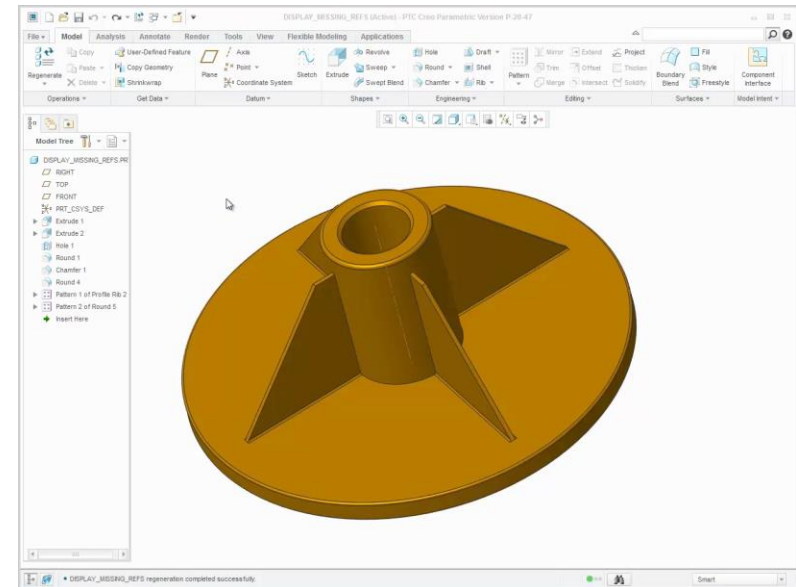
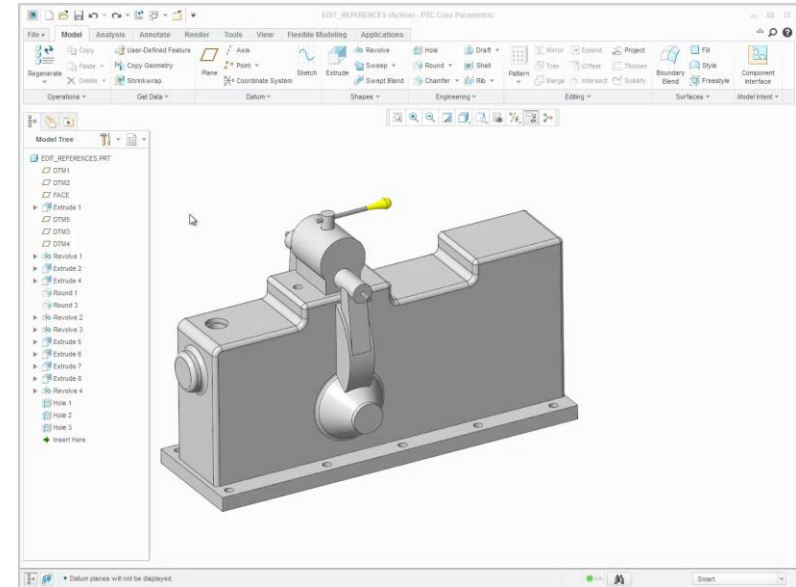

Pattern Enhancements

Capabilities

- Ref pattern from any pattern member
 - Features to be reference patterned can reference any pattern member, not just the pattern leader
- Geometry Pattern Enhancements
 - Now handles topology change using attach option
 - Pattern only quilts with Copy option

Benefits

- Improved usability
- More flexible Reference Pattern workflows
- More flexible and robust Geometry Pattern

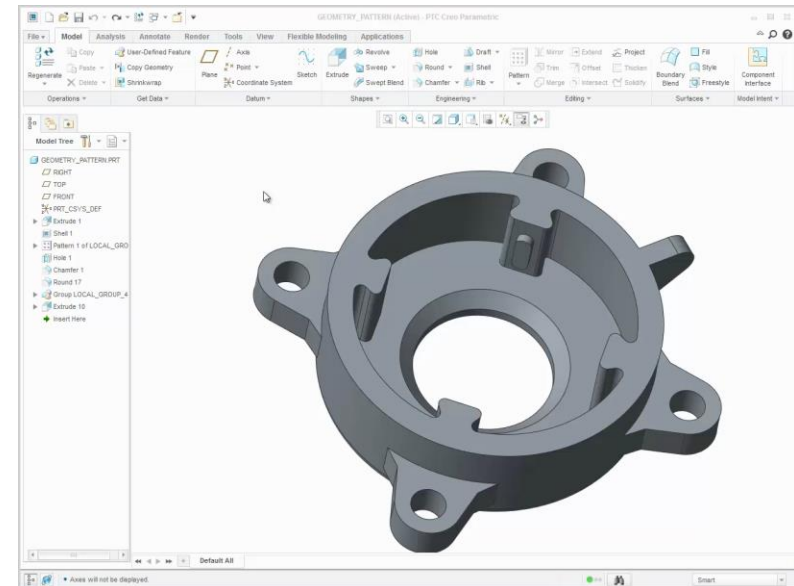
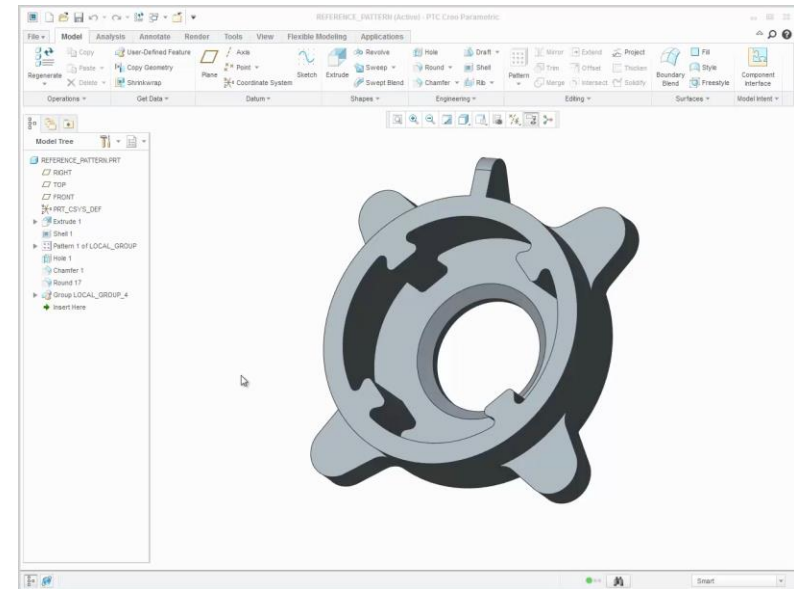

Enhanced Capabilities

Capabilities

- **Enhanced Collapse feature**
 - Collapse any features into either independent or incremental geometry
 - Ability to keep Analysis, Annotation, Publish Geometry, & Cosmetic Features
- **Increase max draft angle up to 89.9 deg**
 - In draft feature and tapered extrude

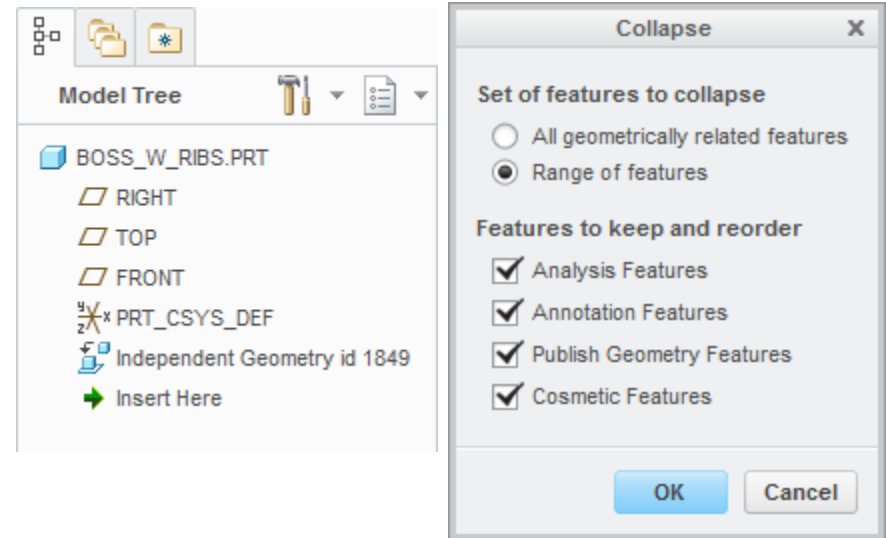

Benefits

- Simplify feature tree more easily
- Increased design flexibility
- Improved usability

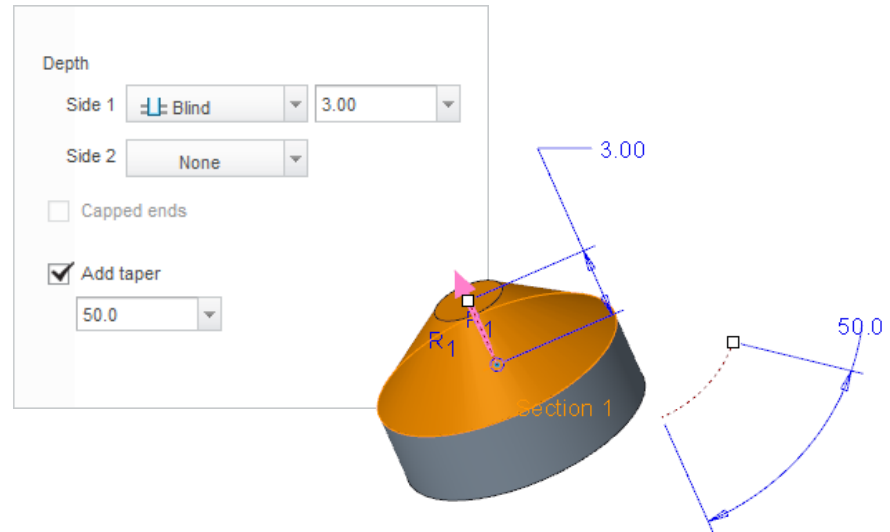

New Surfacing tools

Capabilities

- Ability to un-trim a surface or quilt
 - Un-trim to domain or envelope
 - Available through copy/paste
 - Fully associative to original surface
- Chordal Round
 - Constant width rounds
 - Options for conic or C2, with shape controls
 - Rolling ball and Normal to Spine options

Benefits

- More easily understand and change imported surfaces
- Build more attractive geometry

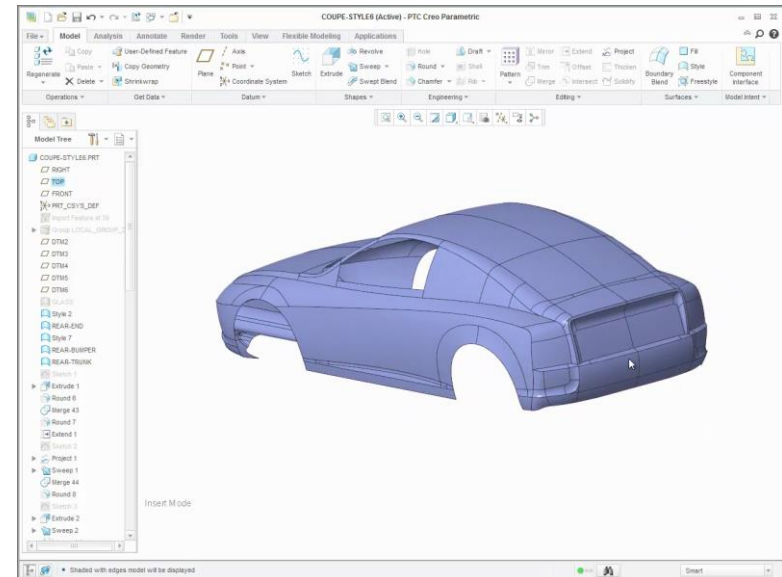
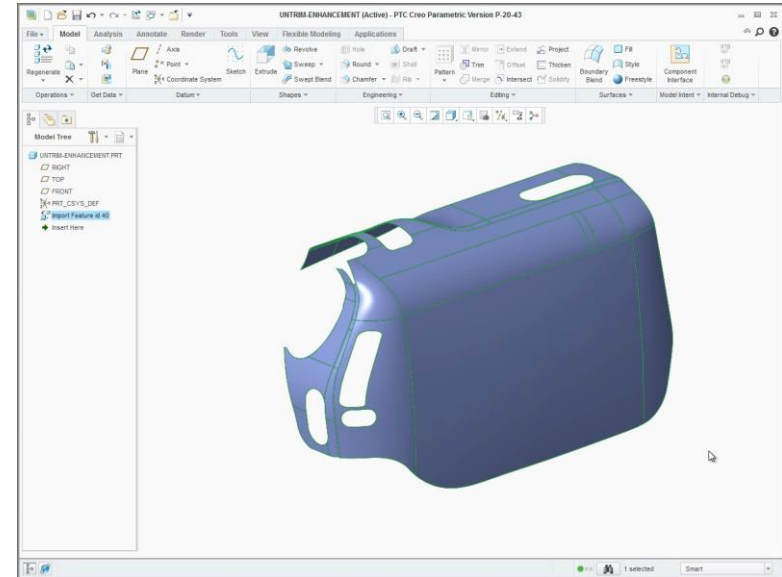

Enhanced Surfacing tools

Capabilities

- **Boundary Blend improvements**
 - Improve boundary Blend surface quality
 - Generates degree 5 surfaces
 - Option to optimize shape
 - Improved connections
 - Improve internal continuity
- **Enhanced Flatten Quilt**
 - Ability to flatten non rectangular surfaces, quilts and solid geometry
 - Symmetry support

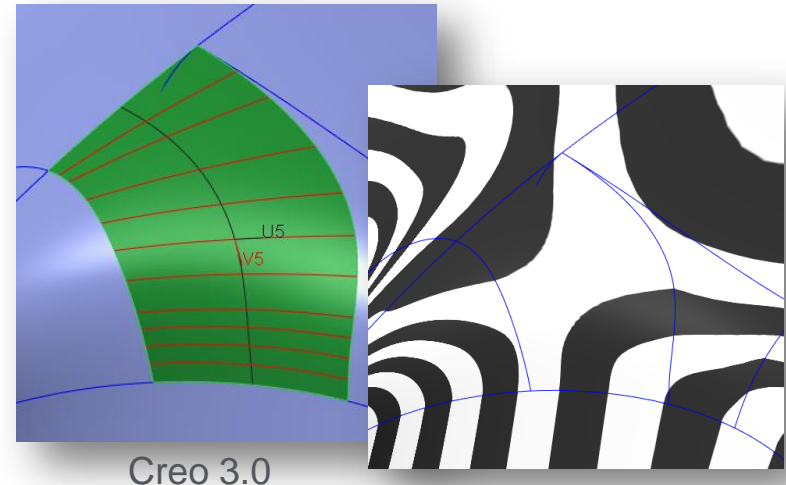

Creo 3.0

Benefits

- Surface quality and connection quality improvements
- Improved productivity

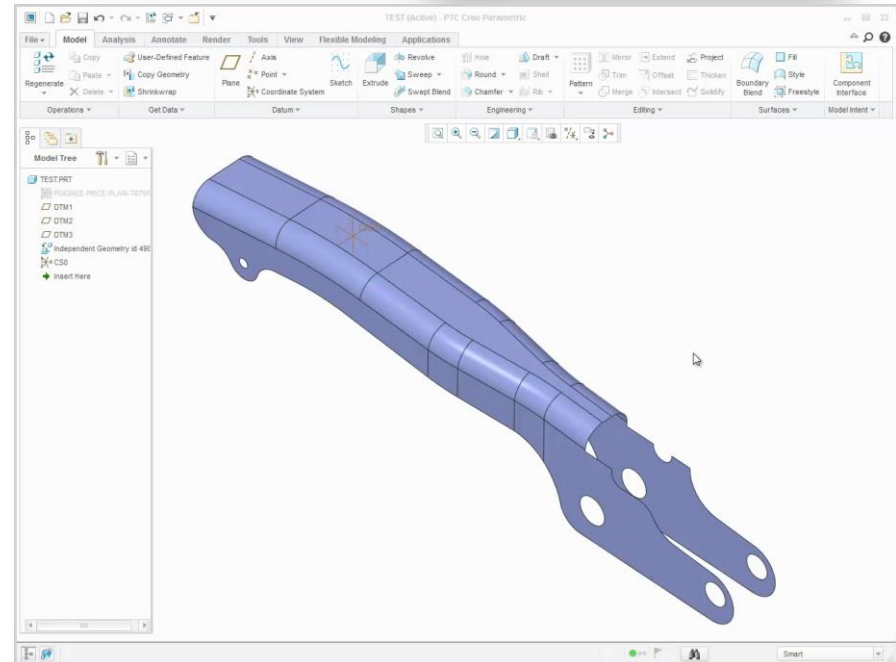

Connection Analysis tool

Capabilities

- Ability to evaluate geometry connections
 - Surface to Surface, 2-sided edges, All edges, Curve to Curve
- Analyze for G0, G1 and G2
- Information displayed
 - Min/Max deviation
 - Color areas outside tolerance
 - Option to show porcupine curve
- Control over tolerance to check against

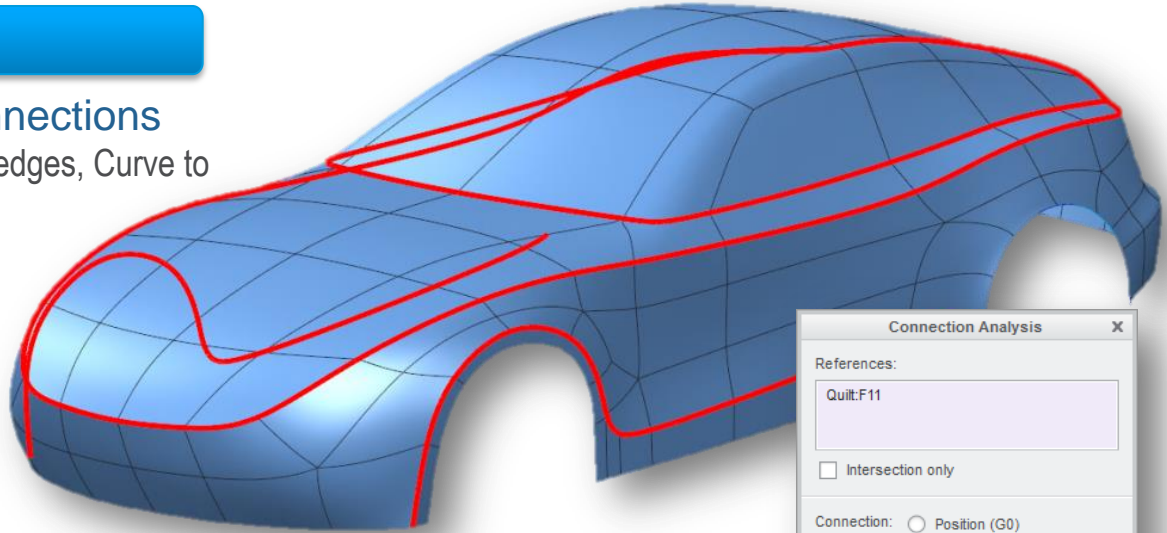

Benefits

- Ability to validate curve and surface connections

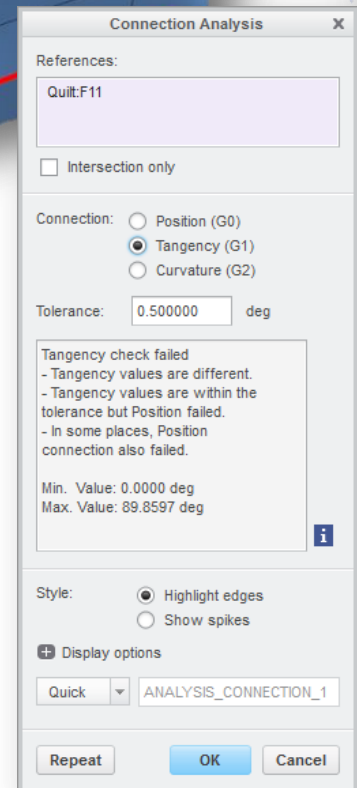

New and improved analysis tools

Capabilities

- More realistic display of Draft Analysis
 - Align result display with Display Style
 - Lighting support provides understanding of depth
 - Support for less than 3 and 4 colors in color plot
- New 3D Thickness Check
 - Perform a wall thickness check for plastic and cast parts
 - Supporting check both on Part and Surface
 - Minimum thickness displayed
- Knot Analysis
 - Display knots and/or control mesh for b-spline surfaces and curves
- Reflection Analysis
 - Control whether to use model color

Benefits

- Identify design flaws and eliminate late-stage rework of production tooling
- Reduce the time to analysis wall thickness of complicated parts and improve accuracy for identifying potential design issues

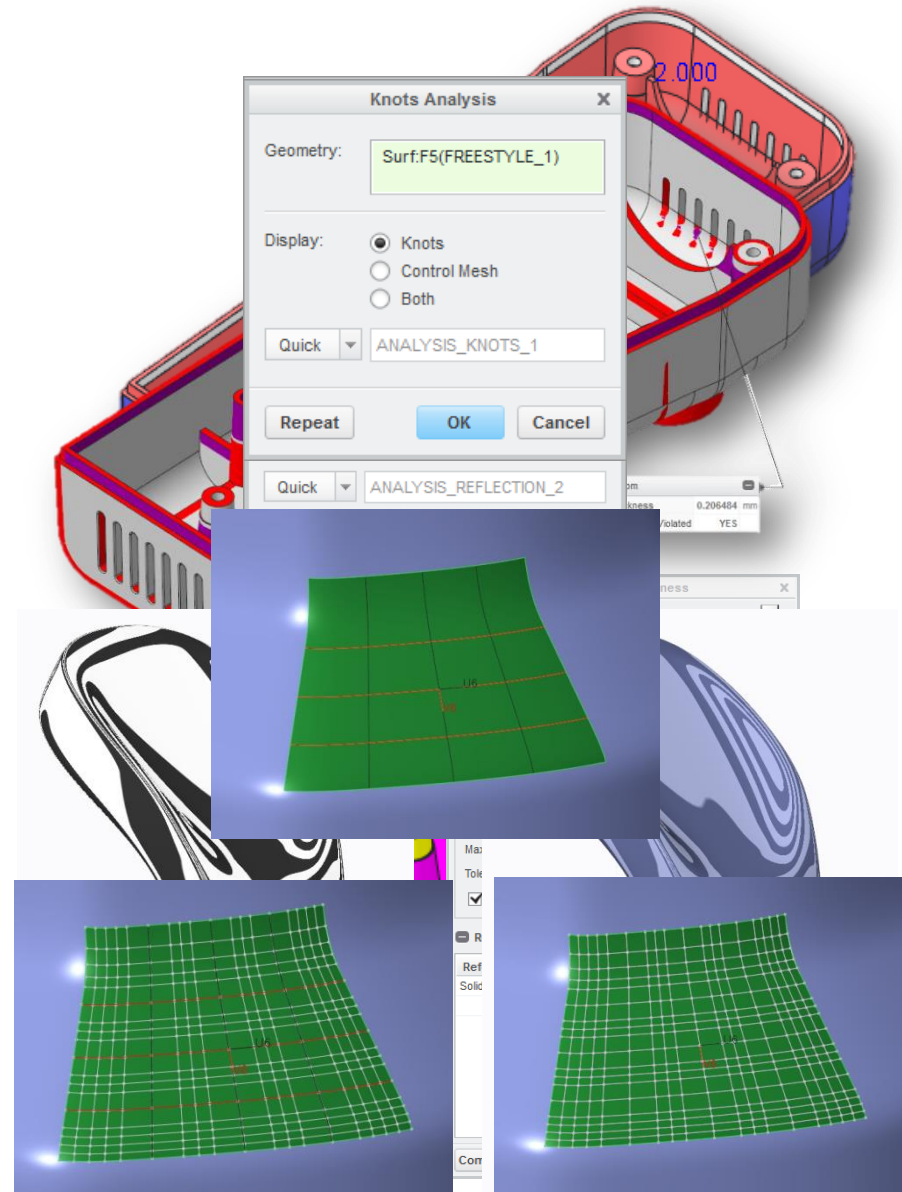

Form Improvements

Capabilities

- New UI and Workflows for Die Form
 - Similar to Punch Form
 - Ships with standard examples
 - Pocket is automatically found
 - Change it easily in the tool
 - Pre-define it in the reference model
 - Use Annotation Elements to pre-define
 - Pocket
 - Excluded Areas
- Flatten geometry attached to forms
 - Flatten Form supports unbent geometry
 - Flat Pattern unbends walls on forms first

Benefits

- Improved productivity and user experience
- Increased design flexibility

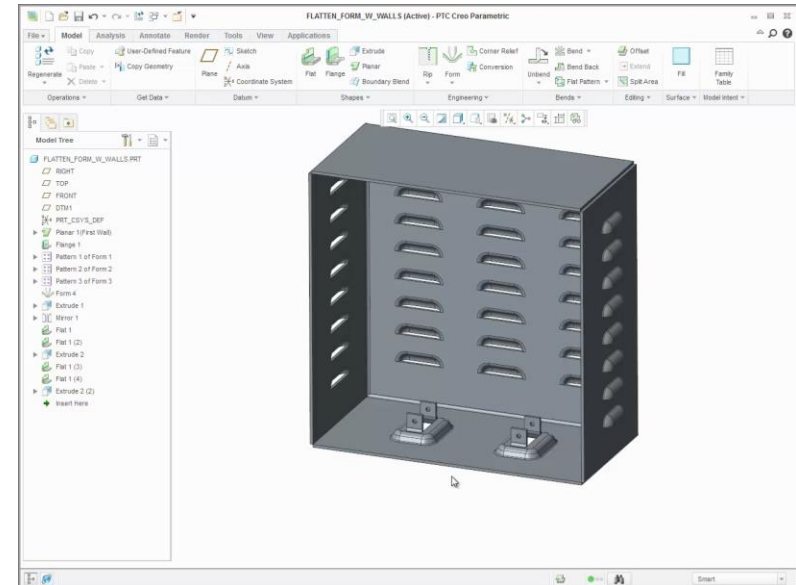
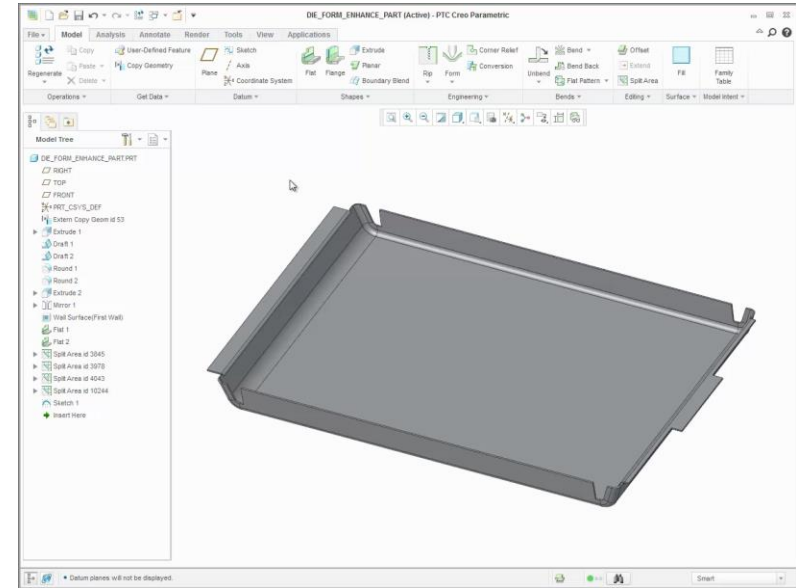

Bend Tool Improvements

Capabilities

- Bend Multiple Planes
 - Apply bends to multiple co-planar surfaces
- Bend Line Relief Placement
 - Relief cuts normal to end of bend line up to bending plane boundary
 - No Relief extends bend to bending plane boundary
- Create Multiple Bend Reliefs
 - Reliefs created as appropriate, not just at bend line ends



Benefits

- Improved productivity and user experience
- Increased design flexibility

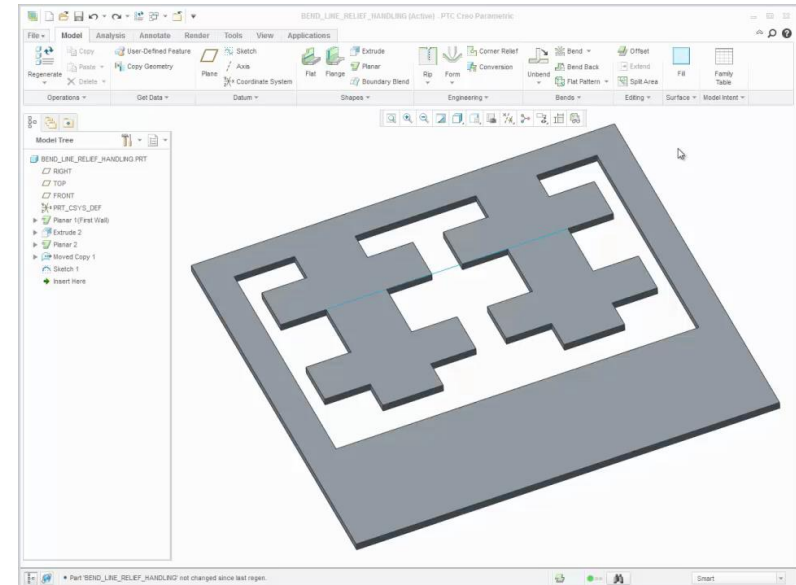
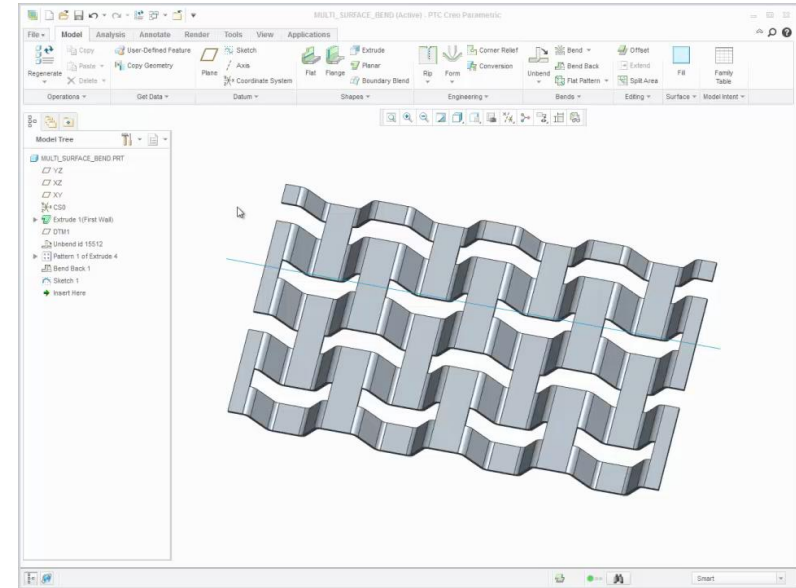

Rip Improvements

Capabilities

- Rip between different contours on the same surface
 - Sketched Rip
 - Rip Connect

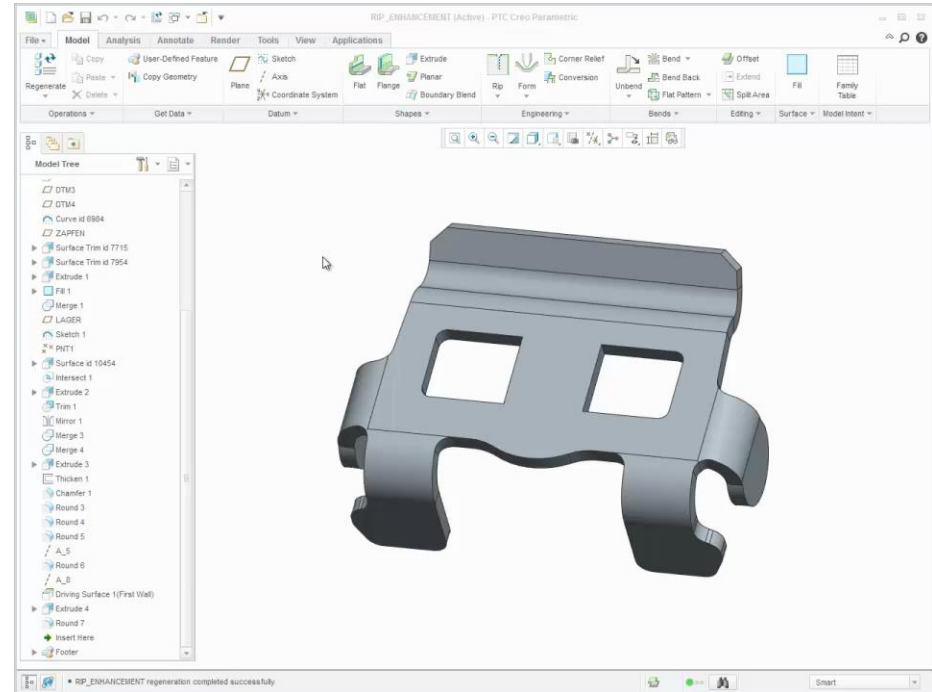

Benefits

- Increased design flexibility

Rounds and Chamfers

Capabilities

- Support for non-circular rounds
 - Symmetric and asymmetric conic and C2 rounds
 - Removed and recreated in Flexible Modeling tools
 - Edit Round - Circular, Conic, C2, D1 x D2 Conic, or D1 x D2 C2
- Chamfer handling and editing
 - Removed and recreated in Flexible Modeling tools
 - Edit Chamfer – DxD, D1xD2, Angle x D, 45 x D, OxD, O1xO2
- Round/chamfer recognition feature
 - Control how the system treats individual round-like and chamfer-like geometry

Benefits

- Preserve engineering intent of non-circular rounds and chamfers
- More flexible and predictable geometry handling

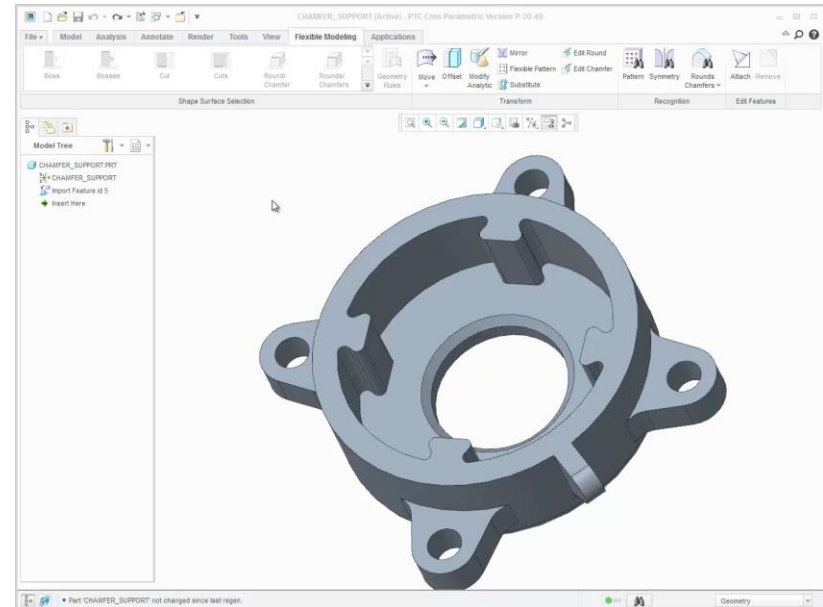
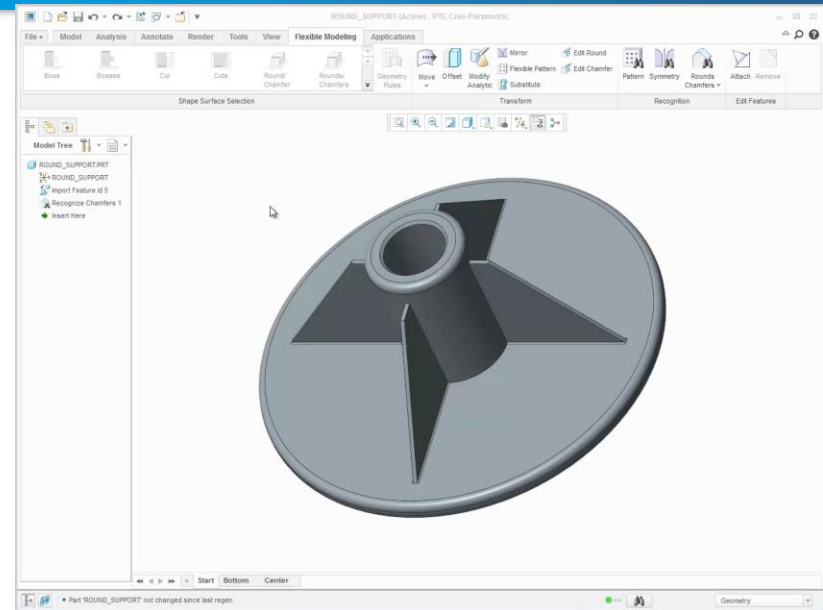

Patterns

Capabilities

- **New Flex Pattern tool**
 - Ability to pattern geometry with flex support
 - Rounds/chamfers are removed and recreated
 - Pattern instances are attached and merged to the solid
- **Pattern propagation from any member**
 - Make Flex changes to any pattern member
 - Propagate changes to all other pattern members
- **Propagation of user defined bounding edges**
 - Can propagate Flex changes with user defined bounding edges to the pattern

Benefits

- Pattern geometry regardless of topology change or presence of rounds or chamfers
- More flexible modeling workflows

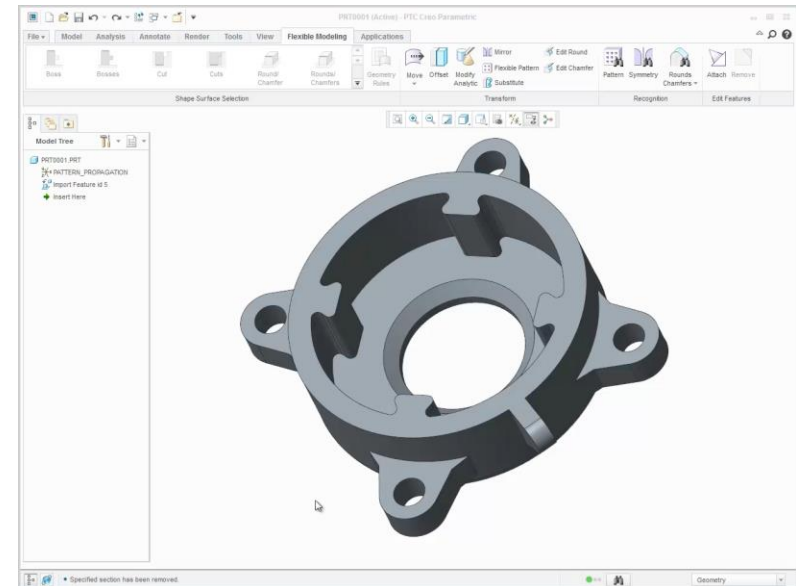
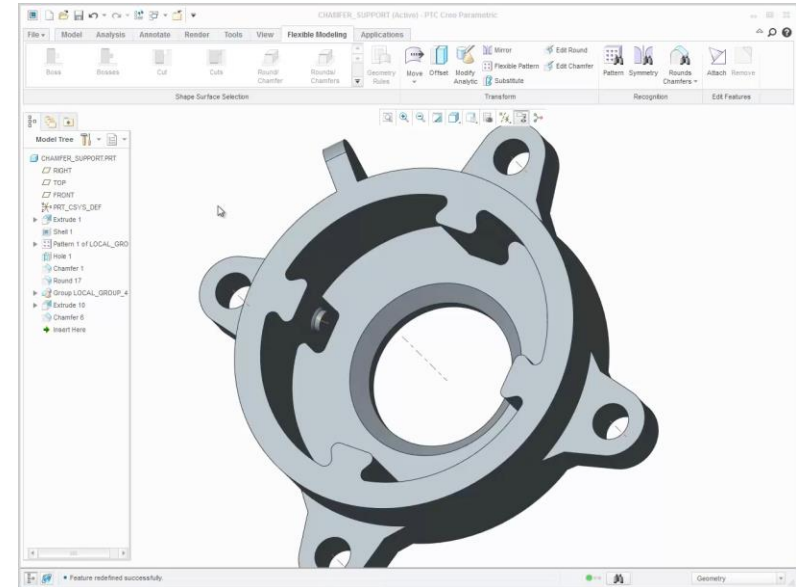

Flexible Feature Enhancements

Capabilities

- **Tangency propagation option**
 - Maintain tangent connections from modified geometry to adjacent geometry
 - Apply conditions to moving geometry (i.e. Fixed, Fixed Axis, Propagate Through, etc) to control how it is adjusted
- **Pull option**
 - Option to attach moved geometry by creating side surfaces along the boundary of the moved geometry, or by extending the neighboring surfaces
- **Inferred refs for Move by Dimension**
 - Ability to infer an axis when a cylinder is chosen

Benefits

- Ability to modify more complex geometry
- Improved workflows
- More predictable results

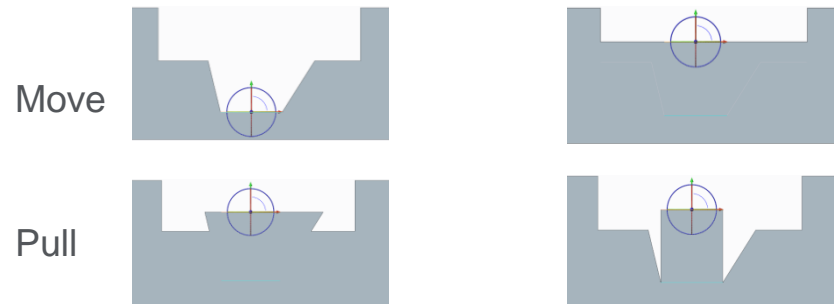
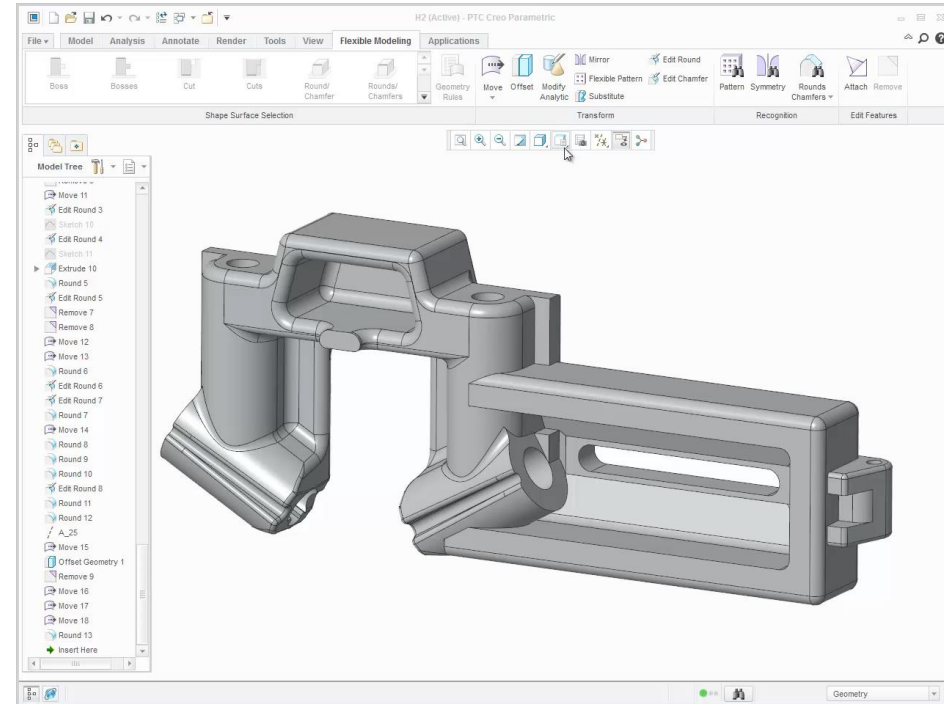

Sweep Enhancements

Capabilities

- Support for high degree curves
 - Degree of surface will be defined by degree of curves
- Support for constraints
 - Boundary edges can have connections applied (Normal, Tangent, Curvature, Draft)
- Support for sweep when profile does not touch trajectory
 - i.e. sweep circle along a curve. For planar profiles only

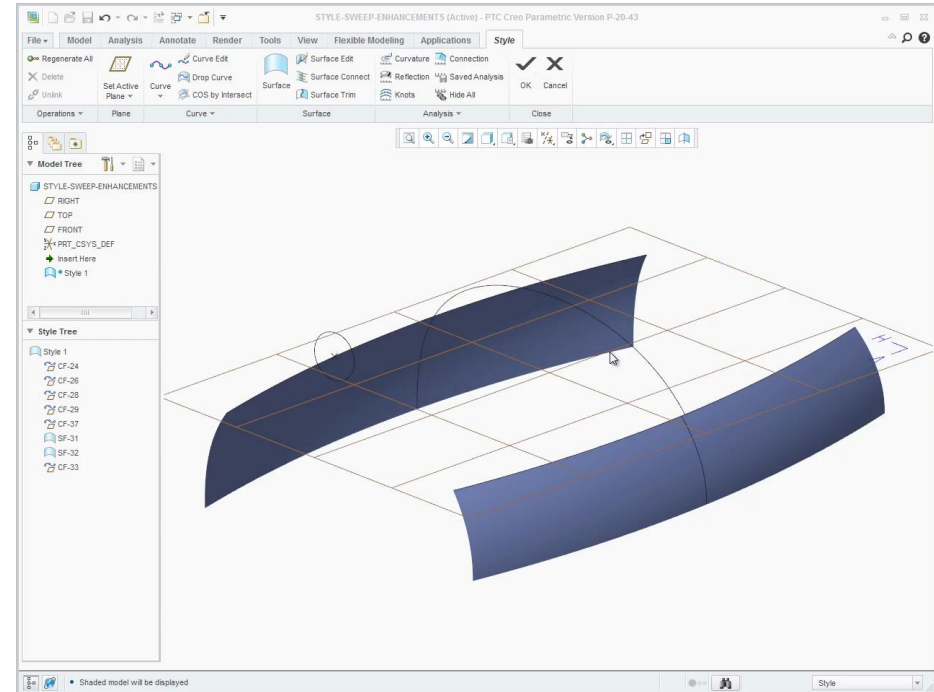

Benefits

- Build smoother surfaces and connections
- Control over connection type
- More intuitive and less steps to build geometry

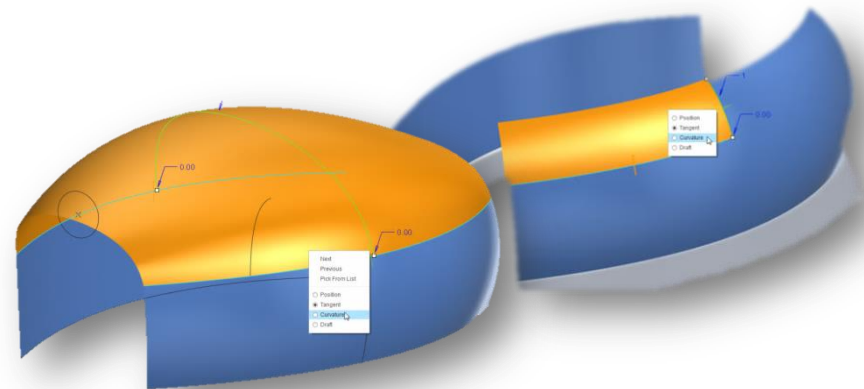

Curve from Isoline

Capabilities

- New option for Curve from Surface
- Ability to define a curve on a surface isoline
- Remains an Isoline curve and updates
- Can be converted to a COS or Free Curve

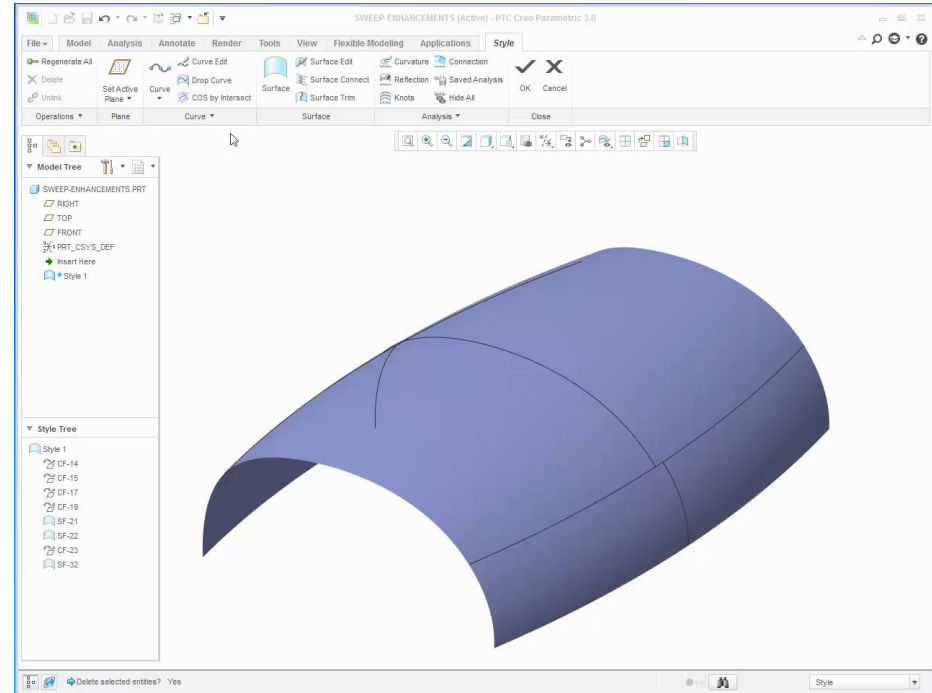

Benefits

- Build smoother surfaces and connections
- More predictable shape change

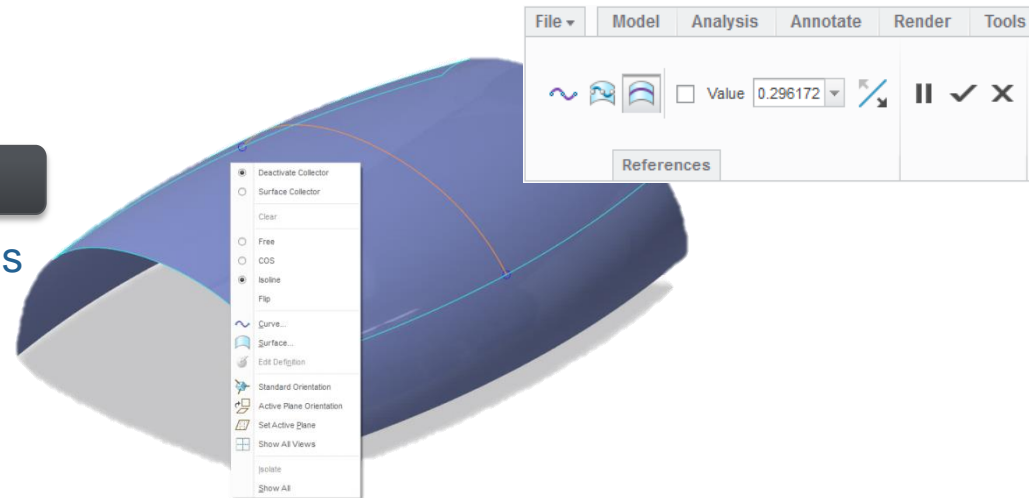

General enhancements

Capabilities

- Geometry preview default to be solid shaded
 - Consistent with feature attach preview
- Option to control whether to merge surfaces on completion of Style feature
- “Show trimmed Surfaces” default change

Benefits

- Consistent with attached preview behavior
- Easier to visualize
- Greater control over surface intersections

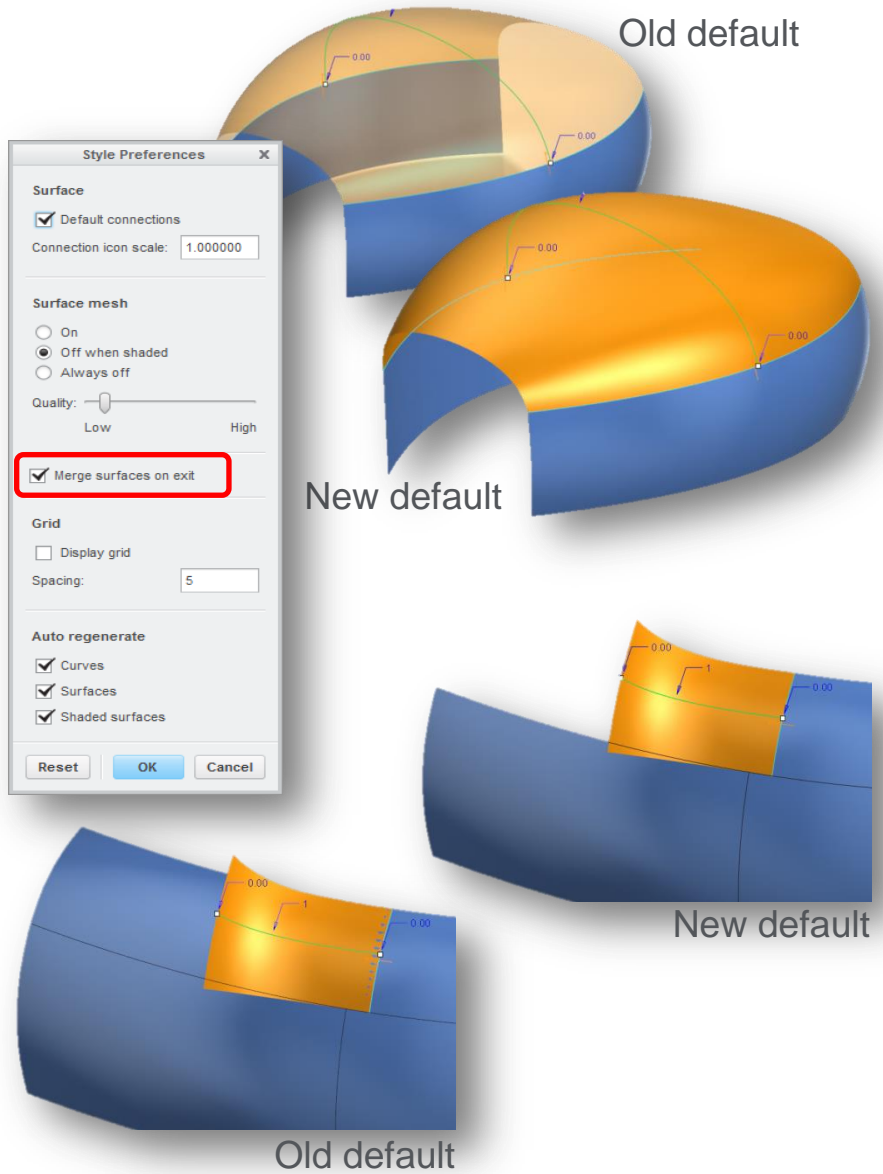

Import Curves from Creo Sketch

Capabilities

- Automatically add Creo Sketch Curves to active Style feature
- Manipulations and scales applied inside “Images” also applied to the curves during import
- Control over visibility of assembly level images

Benefits

- Reuse curves already defined in Creo Sketch

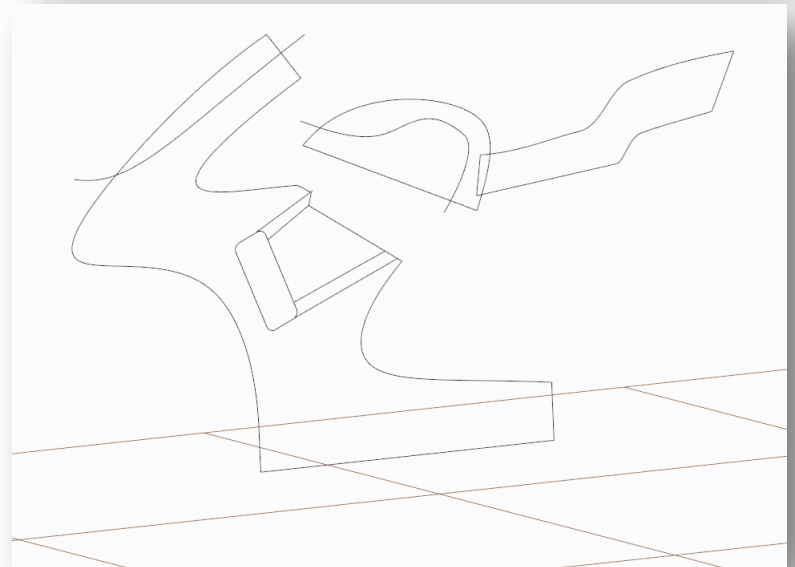
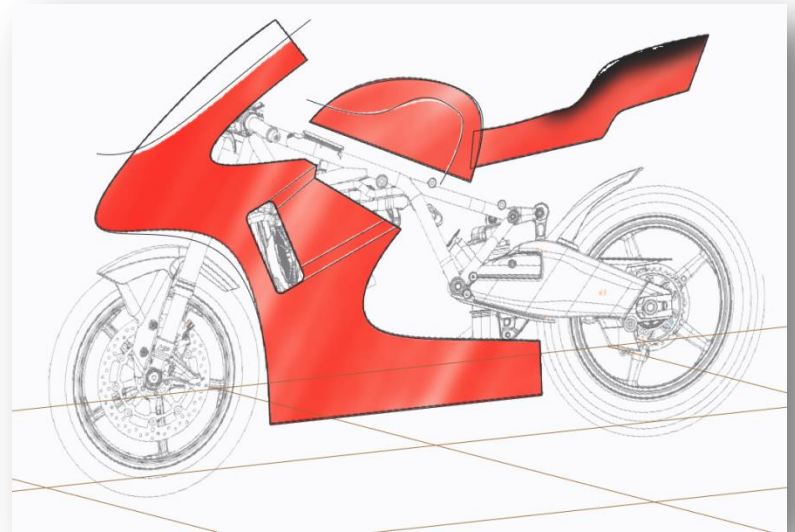

Immersive modeling environment

Capabilities

- Support for realistic materials
 - Different material classes, i.e. Metal, Glass, Plastic, etc.
 - Closely matched to ARX results
- HDR support in shade with reflections
 - HDR image for reflections, lighting and background
 - Control intensity, saturation, rotation, zoom and height
- Realistic bump mapping
 - Bump maps now appear in regular graphics
 - Procedural bumps also supported (in Shade with reflections)
- Ambient Occlusion
 - Occluded geometry is darkened
 - Generated in real-time as the model is rotated

Benefits

- Allowing designers to work in a more immersive environment

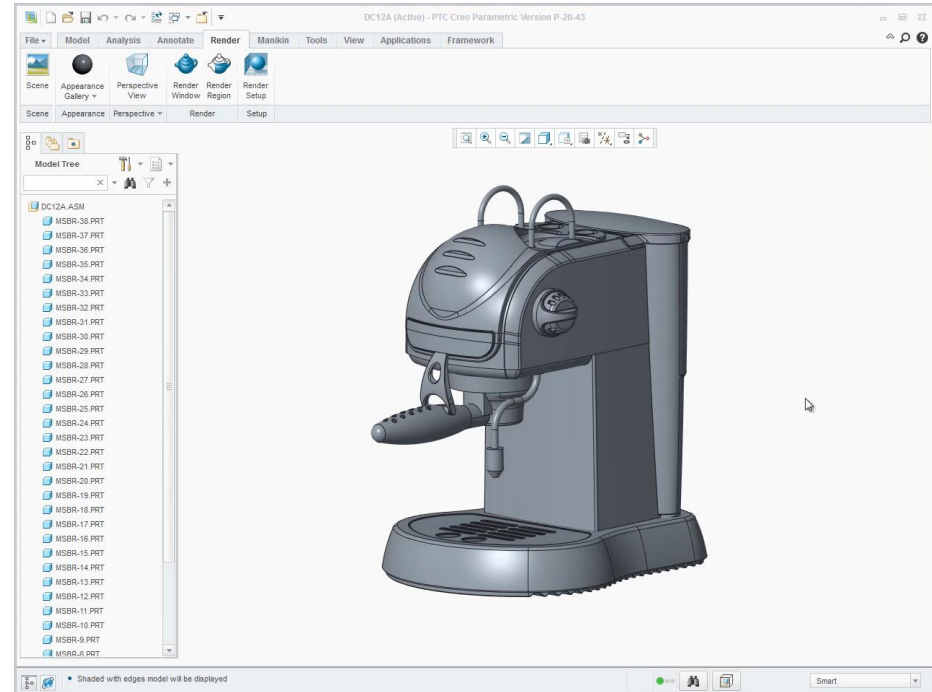

Improved graphics realism and performance

Capabilities

- Improved active component display
- Reorient normal to face
 - Select an edge or face. Model oriented appropriately
- Order independent transparency
 - Improved performance and added support for Nvidia
 - Allows for faster transparency display
 - Less artifacts due to sorting

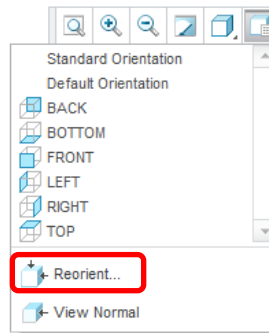
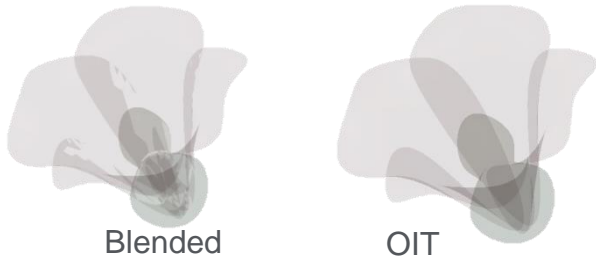
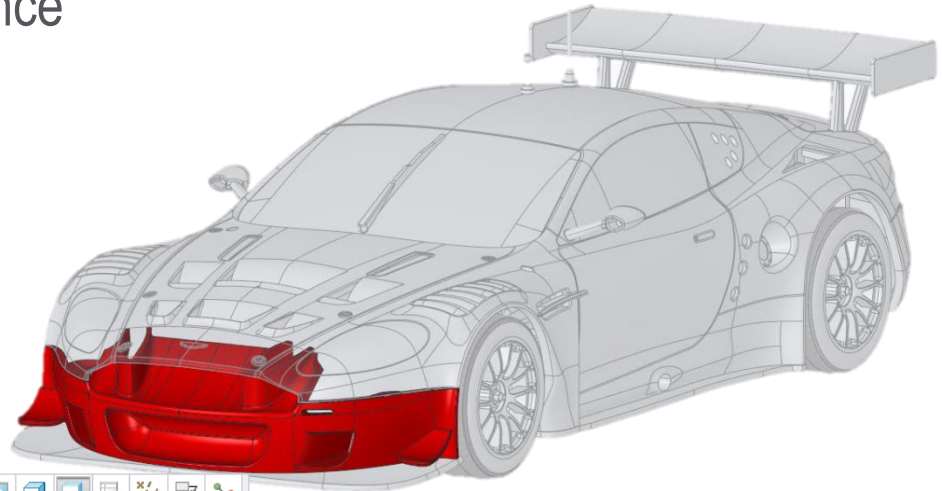

Benefits

- Improved usability in assemblies
- Improved productivity when orienting your model

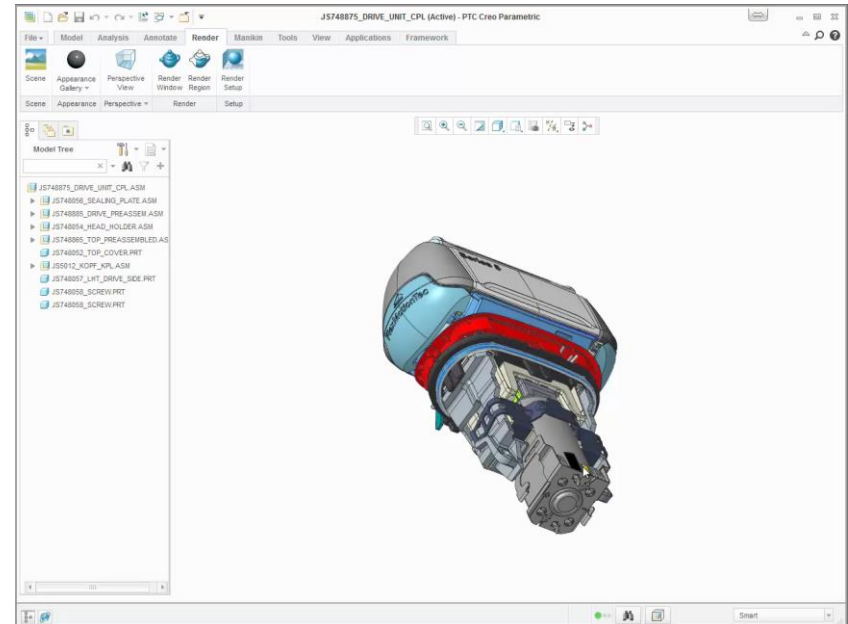

Graphics: Activation – HDR – Appearances – Bump

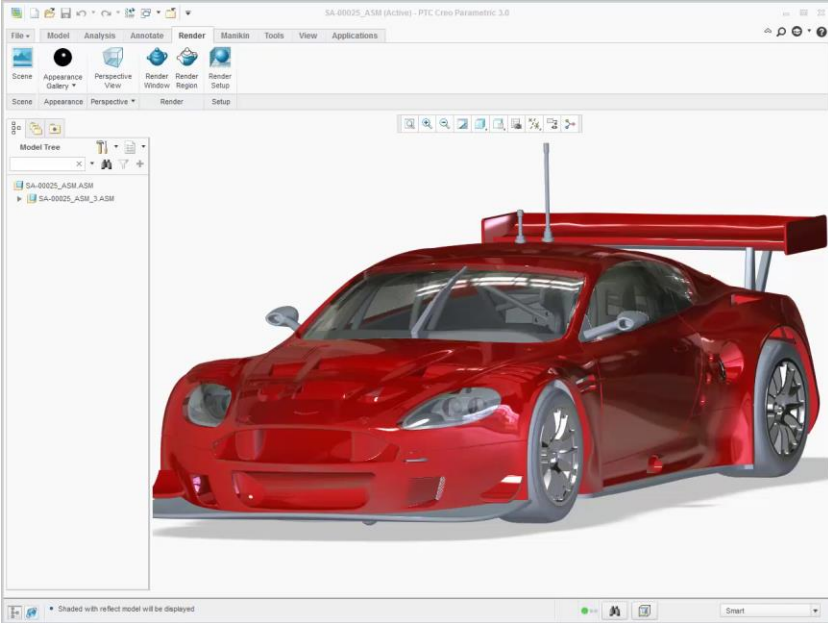
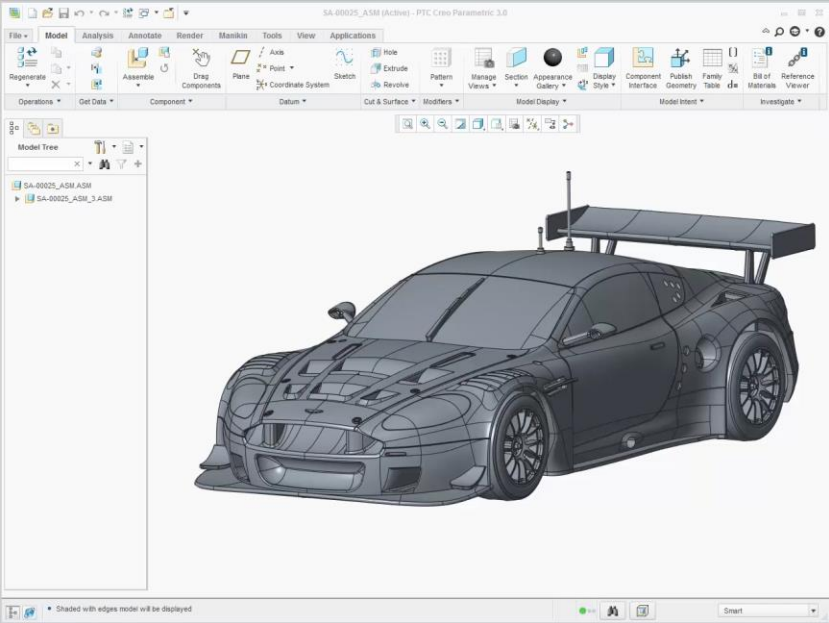
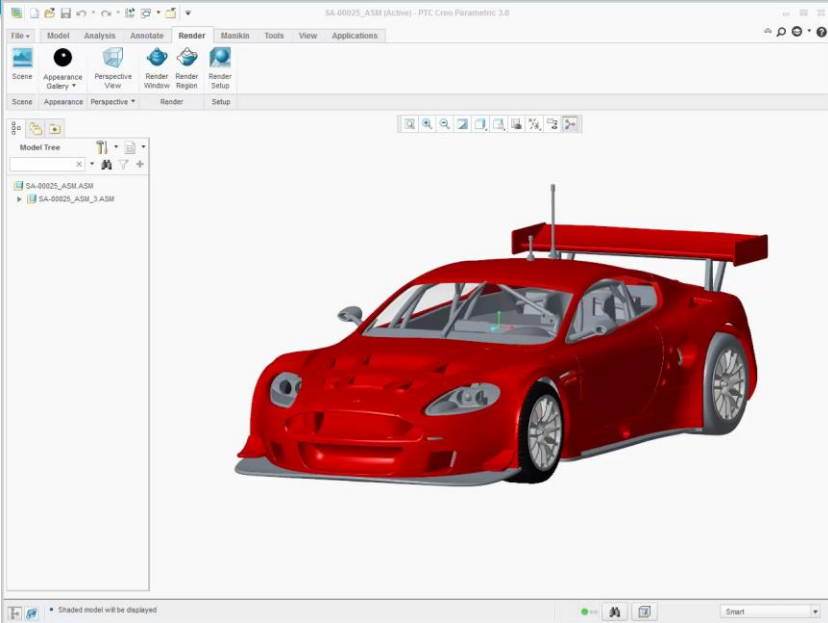
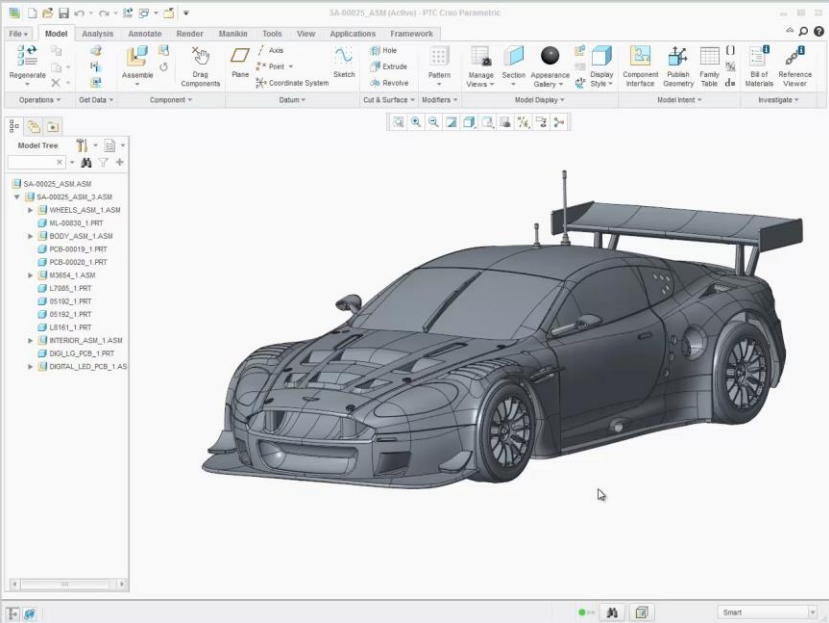

Notification Center

Capabilities

- Comprehensive aggregated status “trail” in the model-tree
- Live indications of changes/issues that require user’s attention
- Single access-point to quickly track/sort/fix common modeling issues
- Automated background PDM sync upon regenerate
- Customized notifications

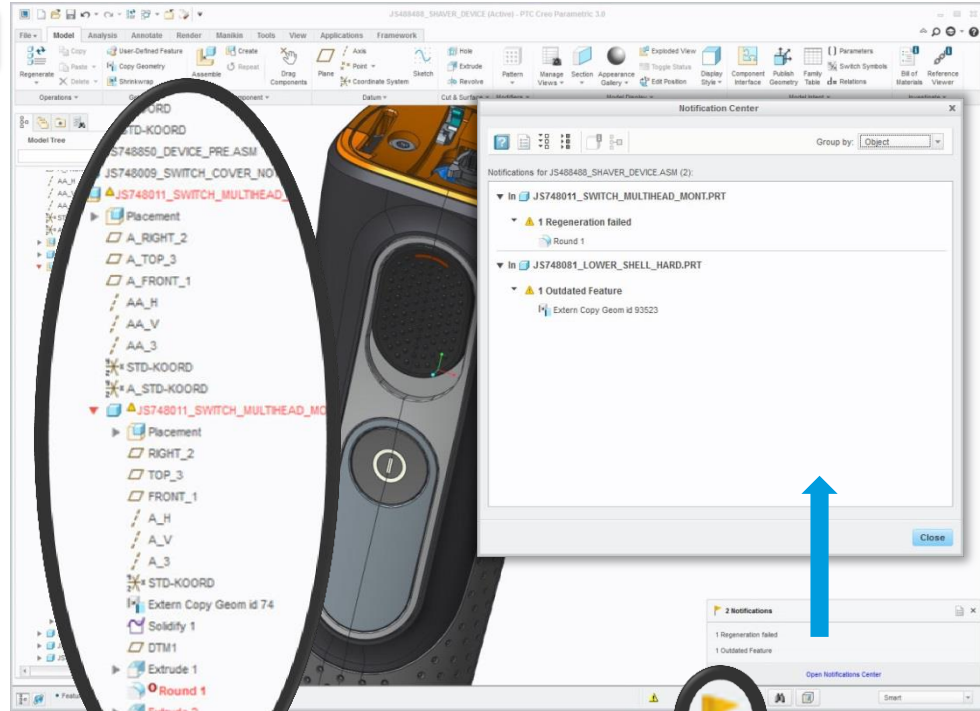

Benefits

- Easier way to identify, locate and fix design issues
- Monitoring design changes and potential problems becomes more user-friendly and intuitive with a unified notification manager.

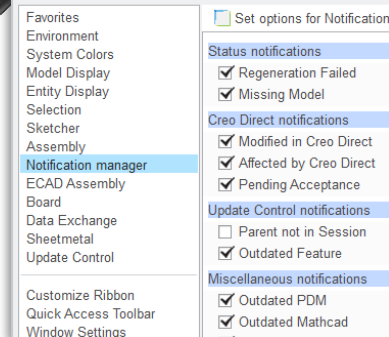

Improved performance and user experience in "Chooser"

*Also back-ported to Creo 2.0 MOR

Capabilities

- Separate graphic refresh from tree manipulations
- Sticky state selection
- Reduced redundant mouse clicks

Benefits

- Popular graphics preview dialogs (simprep definition, envelope manager, variant builder, etc.) work faster and smoother

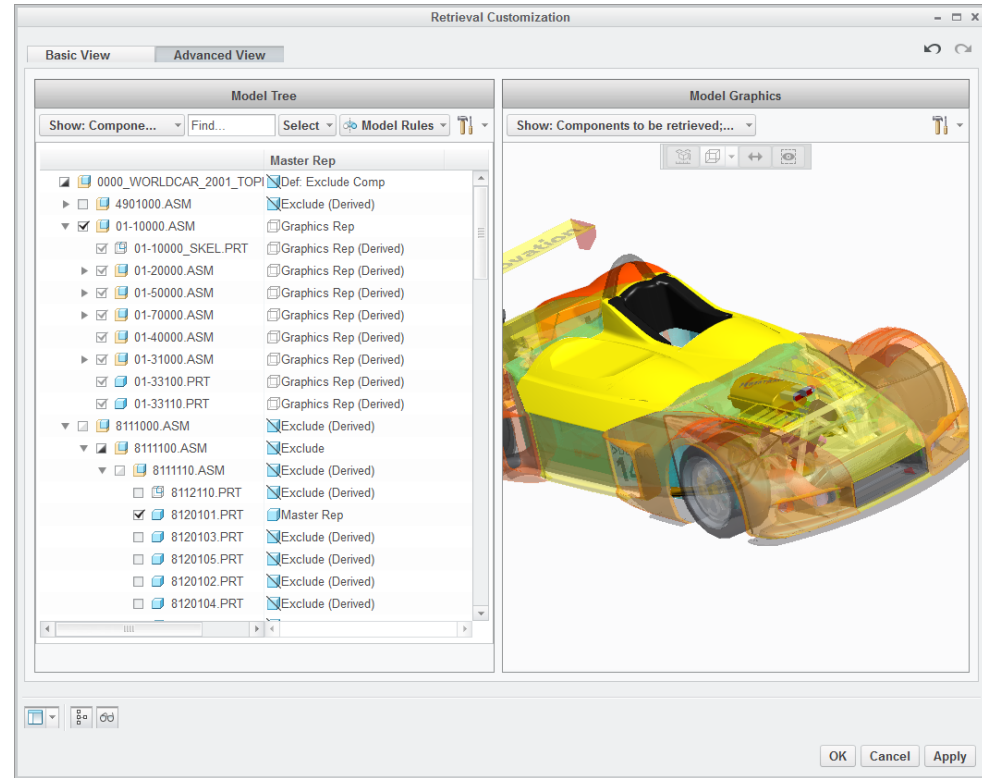

Mass Properties clean-up

Capabilities

- Extended set of MP parameters to indicate SYS and transforms of alternative MP
- Added parameter to define and indicate origin for inertia calculations
- Removed annoyances and repeated prompts

Benefits

- More accurate identification of a need to update MP

(*several fixes also done in Creo 2.0 MOR)

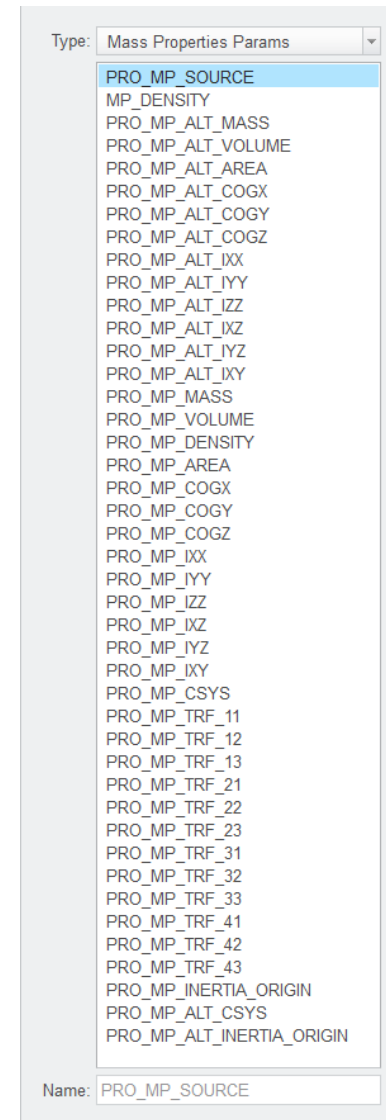

Simplified regeneration states

Capabilities

- Eliminated confusing “Frozen” state, merged with ‘Failed’
- Fix operation replaces Freeze
- Separate feature status vs parent status.
- Separate feature status and parent status. Introduced new columns to report "feature status" and "feature attributes".

Benefits

- More intuitive and consistent reporting of session content and reference models status

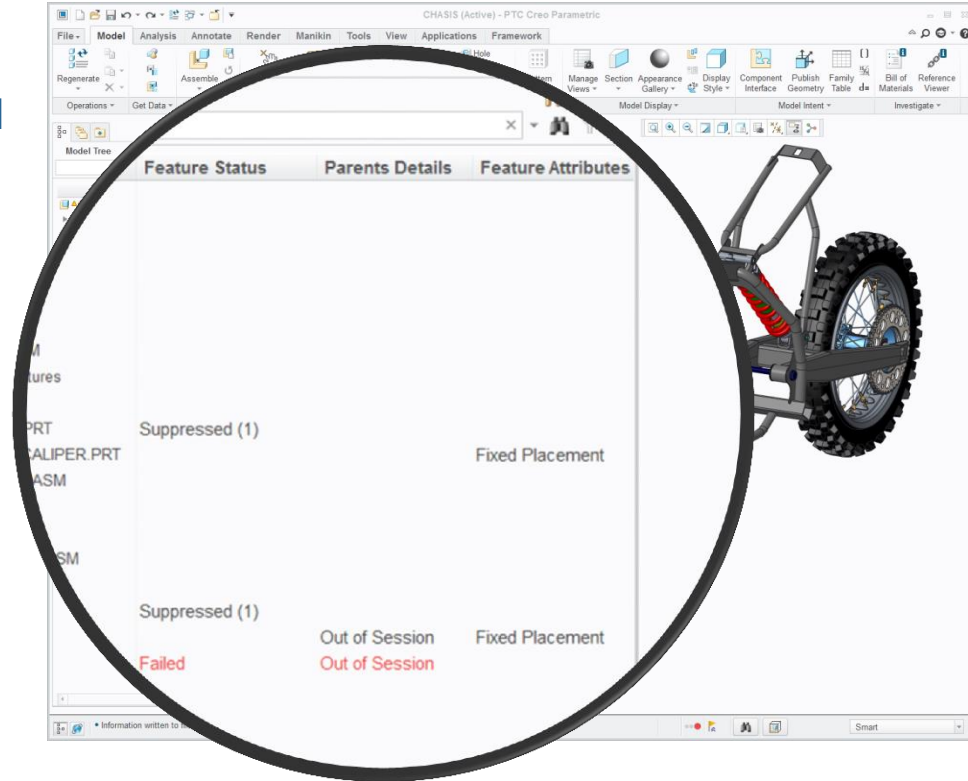

Usability improvements

Capabilities

- Parting Surface – Curve Extend
 - Select edge references directly
 - Support multiple curve sets
 - Automatic ‘Transition’ surface creation
 - Build-in common extension types:
 - Normal, Parallel, Tangent, Normal to Boundary, User Defined
- Parting Surface – Fill Loops
 - Modernized interface
 - Improved workflows and chain selection
- Modernized User Interface for Pull direction

Benefits

- Reduce design cycle time with the intuitive interface and workflow
- Specialized capabilities to automate complex, time-consuming parting designs

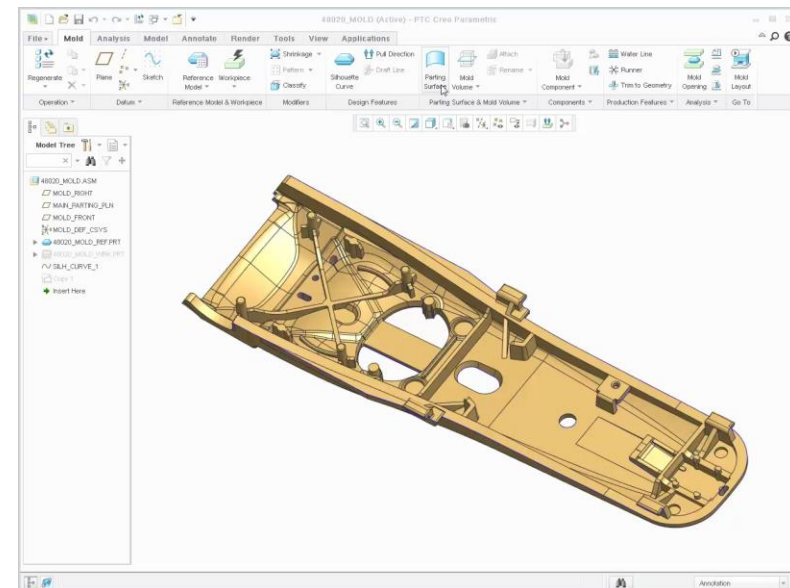
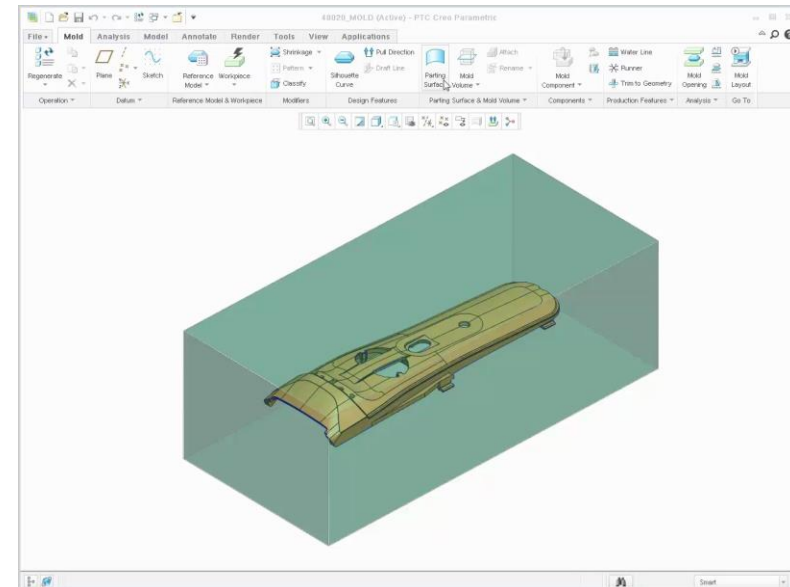

Creo Mold Analysis

Capabilities

- New replacement for Plastic Advisor
- Lite version available on every seat
- Paid version adds more capability
 - 6500 materials
 - Support for multiple gate locations
 - Air trap and weld line simulation
 - Confidence of fill

Powered by **Moldex3D**
MOLDING INNOVATION

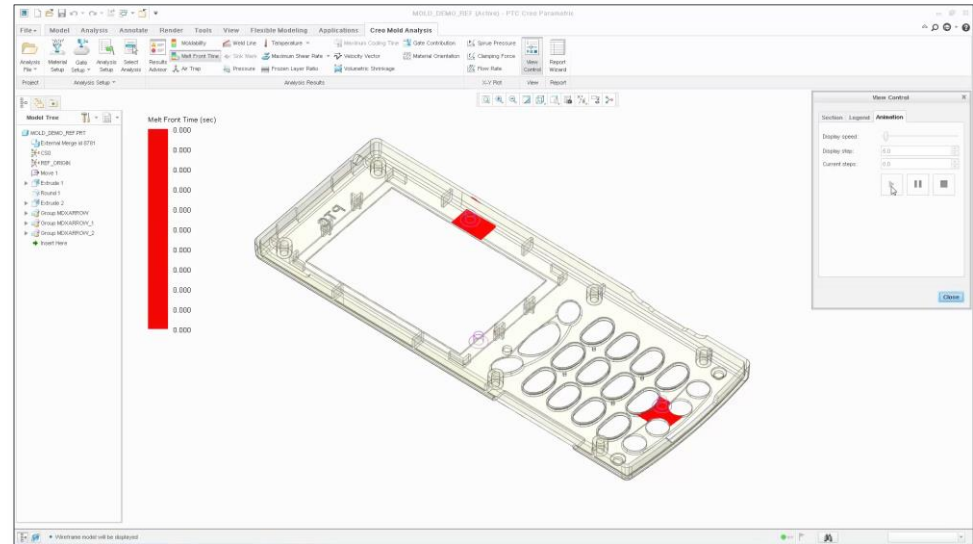

Benefits

- All designers can now perform basic analysis
- Paid version provides confidence of design

Multi-Task Machines Synchronization

Capabilities

- More intuitive user interface
- Synchronize turning and/or milling sequences
 - Synchronize at the start or on a point-on-toolpath
 - Provides two views, Synchronized and machining order
- Visualize synchronization
- Multi-Task work-center definition, (support 4 Heads, 2 Spindles)
- Manage separate tools sets by head
- Support assignment to main or sub-spindle

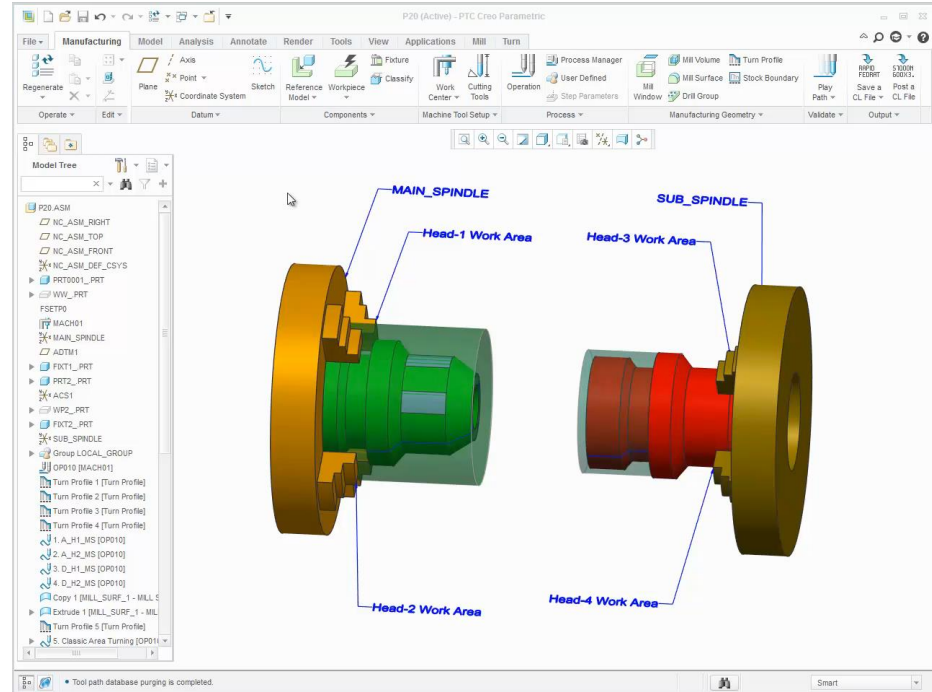

Benefits

- Drive Multi-Task Machines
- Efficient and intuitive workflow to synchronize toolpaths

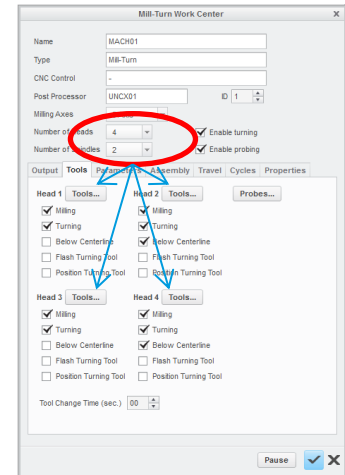
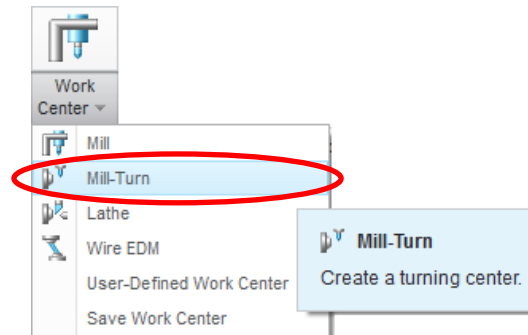

Roughing sequence optimizations

Capabilities

- Implemented 3 major enhancements to roughing sequences:
 - Minimize retracts:
 - For CONSTANT_LOAD, FOLLOW_HARDWALLS (volume milling), and FOLLOW_CONTOUR (roughing and re-roughing) scans.
 - A method to decide when the cutter stays on the surface. If there is a gouging condition the tool will also retract
 - 3 new retract connection options between zones
 - SHORTEST_ROUTE, MINIMAL_VERTICAL, ALWAYS
 - A way to control the retracts by lifting the tool while connecting to the next cut.
 - Exit and entry with an arc or helix.

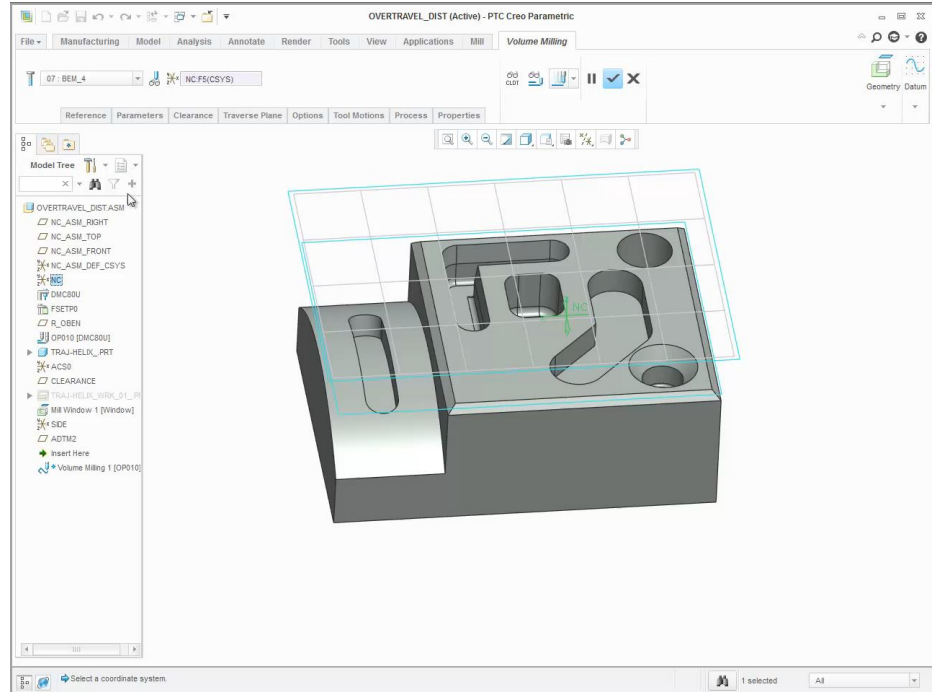

Benefits

- Less “cutting-air” problems
- Less machining elapsed time
- Better and more control over connections
- Better control for machining hard materials

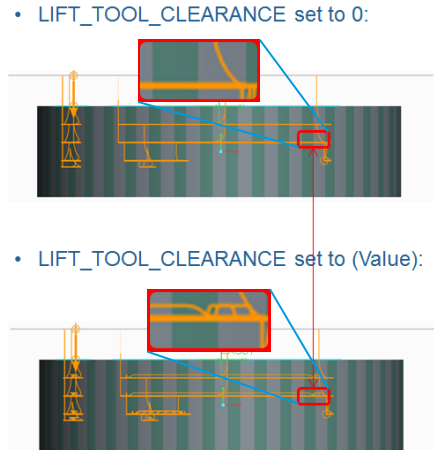
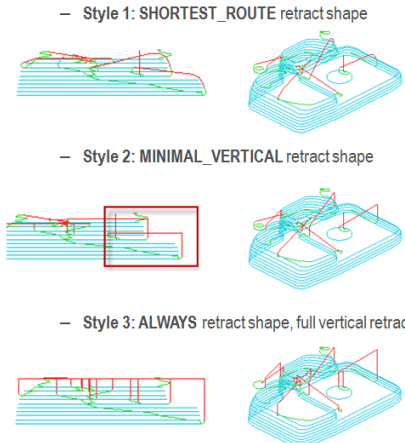

Dynamic tool axis definition

Capabilities

- Implement Tool Axis Control, for curve cuts and drive surface cuts
 - 3 axis
 - Pivot about a Point/Axis
 - At a Location
 - Pivot about a curve
 - Normal to Surface
- Support for corner conditions
 - Loop, Fillet, Chamfer, Loop and Straight
- Support of 4 and 5 Axis Trajectory in Process Manager
- Implement Tool Axis Control, for 5 Axis Cutline Milling

Benefits

- Unlock the potential of our 4 and 5 axes production machining capabilities

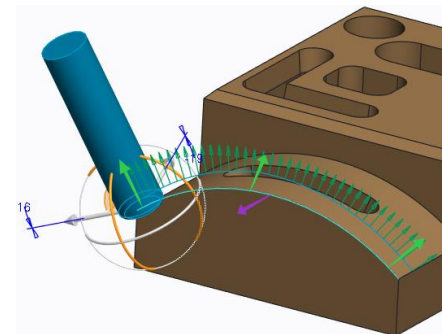
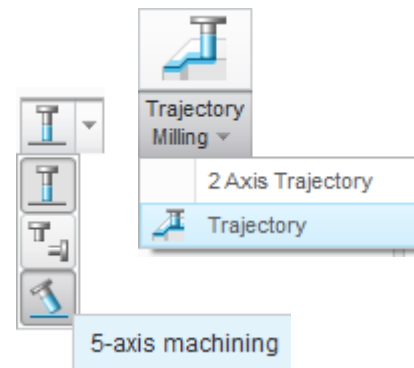
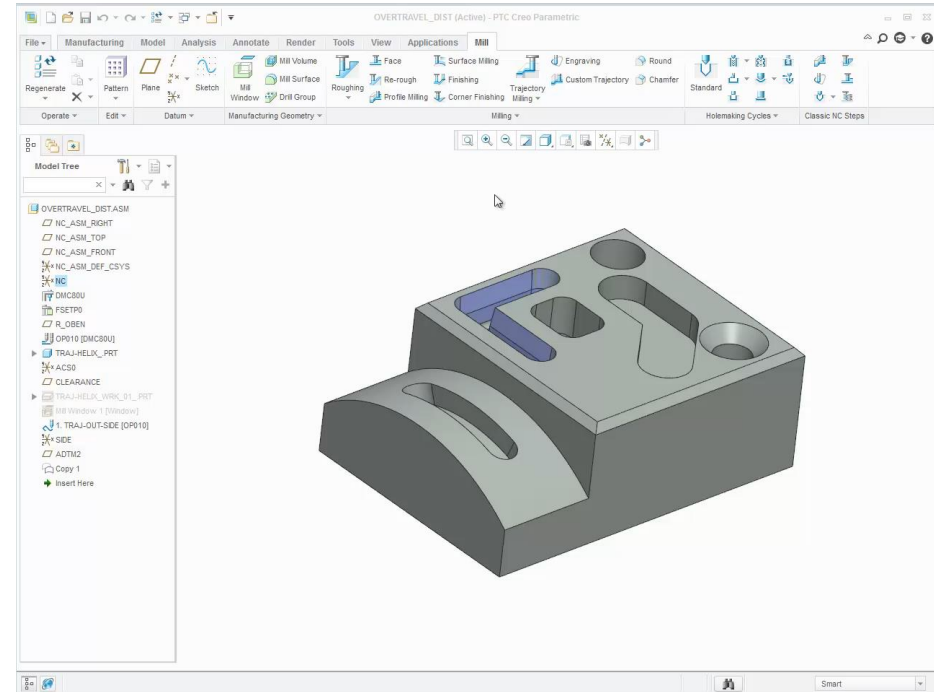

Thread milling/turning

Capabilities

- **Thread Milling**
 - New control added with the following abilities:
 - Straight Thread - cut a straight thread (inside or outside). The default behavior
 - Pipe Taper Thread - cut a pipe taper thread. Corresponds to industry standards; NPT, ANPT, BSP, DIN2999, JIS B0203, etc.
 - Custom Tapered Thread - cut a thread with any taper.
- **Thread Turning**
 - Standardize options for AI Macro and ISO.
 - Keep ISO as the default
 - Reduce the thread milling output choice to be a Basic Parameter.

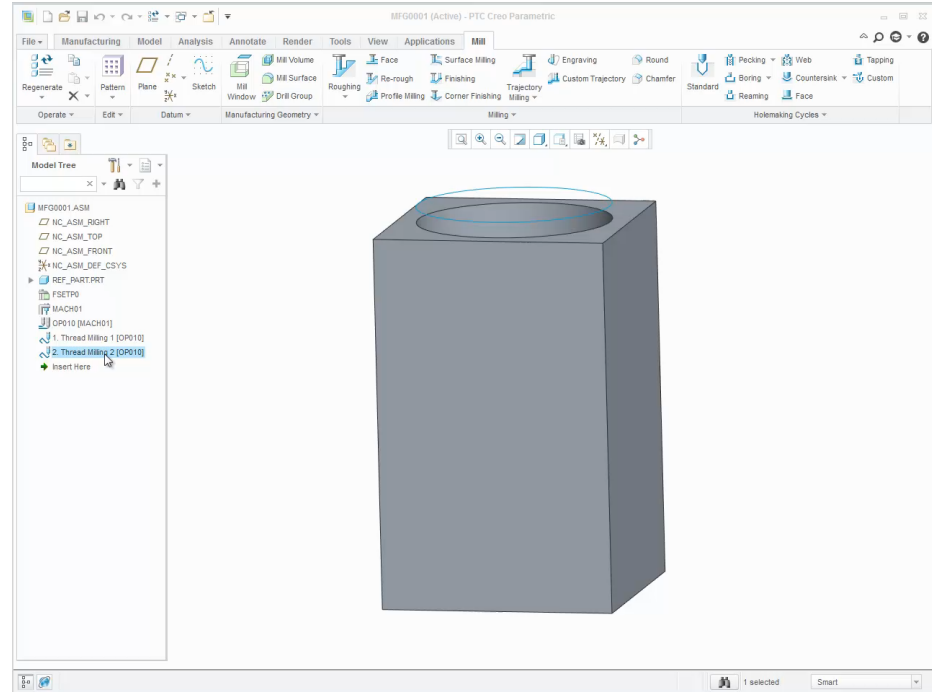

Benefits

- Taper thread milling enhance the multi-step thread capabilities introduced in Creo NC 2.0
- Improved standardization support

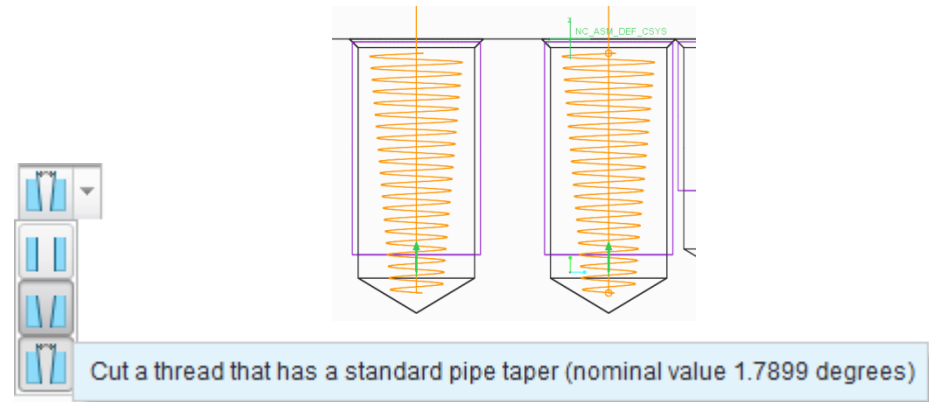

Usability improvements

Capabilities

- UI Modernization
 - NC Steps
 - Volume Milling
 - 4 & 5 Axis Trajectory
 - Tool Axis Definition
 - Synchronize Tool Path
- Align Drag & Drop in NC to Creo Parametric
- Simple Search available for NC, Mold, etc
- Support latest versions of GPOST and Vericut

Benefits

- Volume milling with a new ribbon-based UI consistent with all other NC steps
- Consolidation of Trajectory algorithms under a simple UI to produce 3, 4 or 5 Axis toolpaths

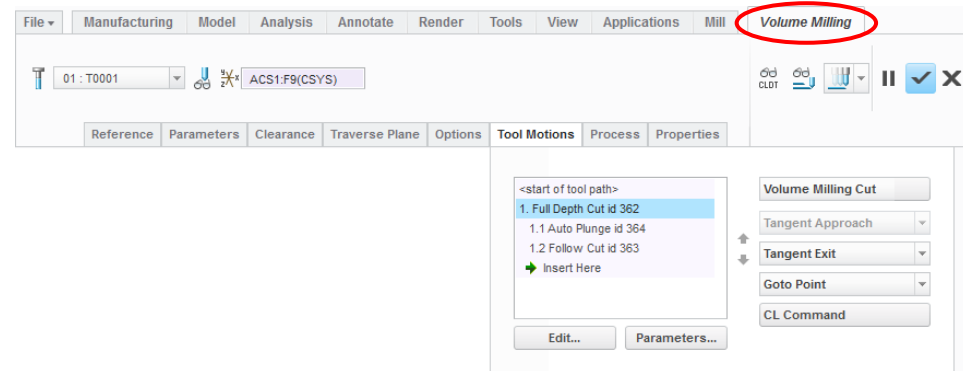
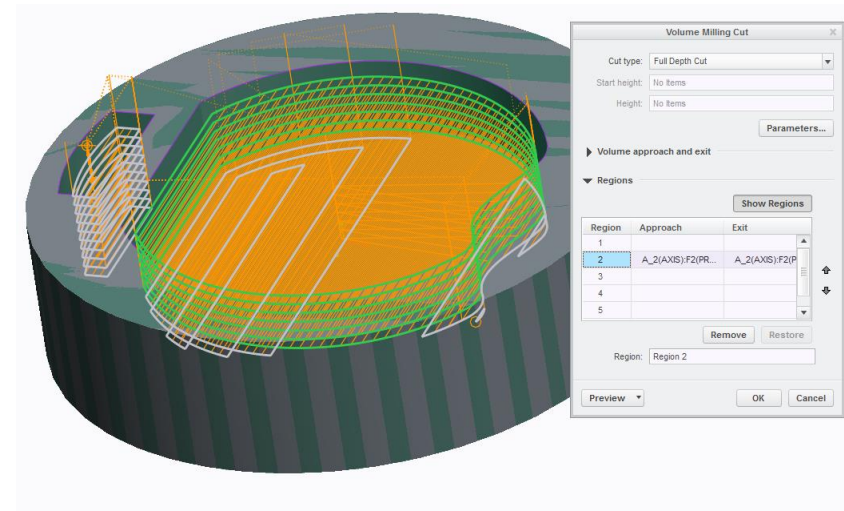

Improved Design Detail and Downstream Data Sharing

Capabilities

- **Bundle Representation Improves**
 - Bundle transitions will provide a more realistic depiction of shrink-wrap tubing
- **Improved Integration with Creo View**
 - Model tree includes more information:
 - Cables
 - Cable contents
 - Wires
 - Ability to select a single wire
 - Highlights in display
 - Wire parameters displayed

Benefits

- Improved realism in bundle display
- Better downstream use of cable design information

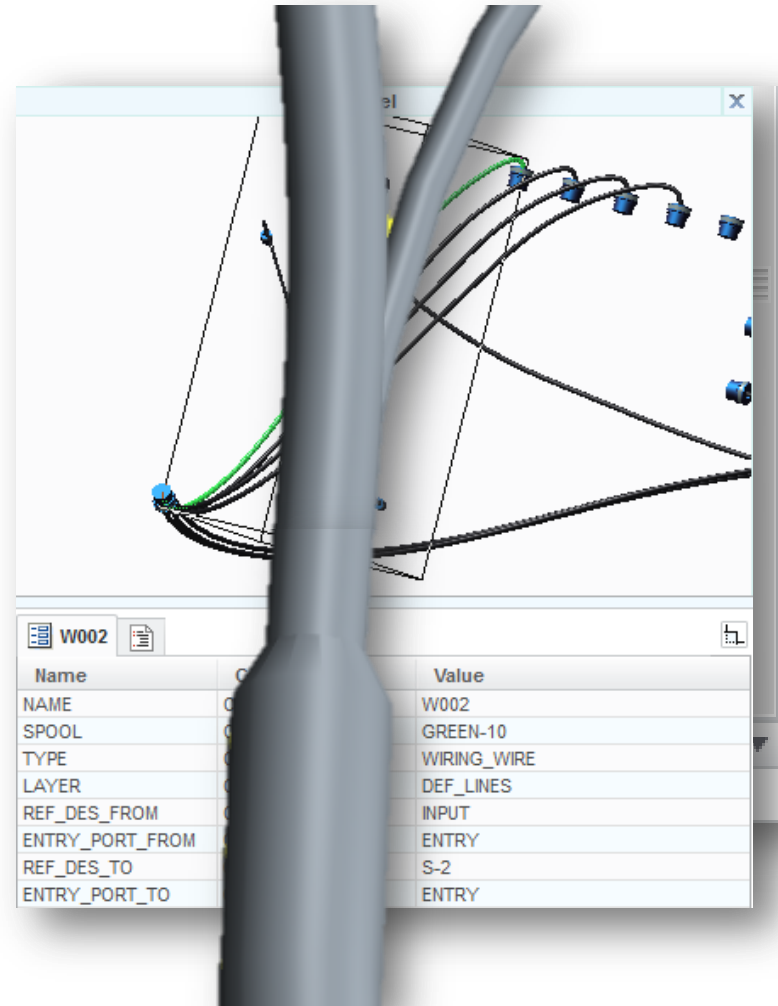

Improved Windchill Integration

Capabilities

- New Assembly Sub Type
 - Unique Identification in Model Tree
 - Utilized for Rigid and Flex board
 - Dedicated ECAD Ribbon
 - ECAD Board
 - ECAD Assembly
 - Streamlined Component Assembly
- Legacy Designs Not Supported
 - Migrate using IDX
- IDF Not Supported

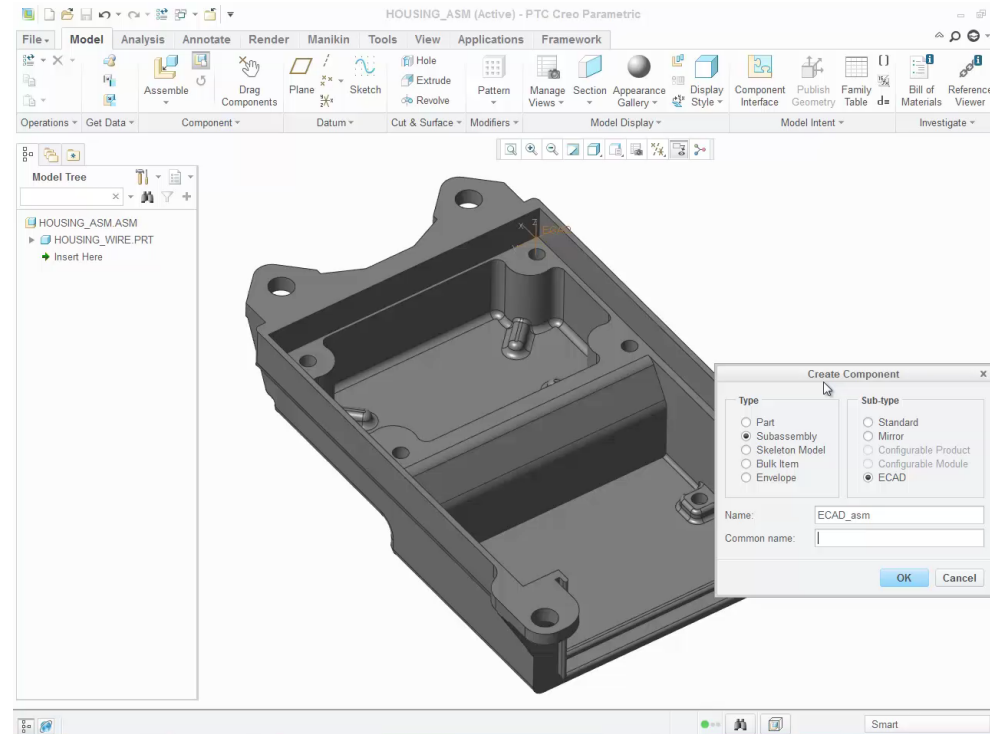

Benefits

- Identify ECAD Assemblies in Windchill
- Faster Component Assembly
- Streamline UI

Consistent User Experience

Capabilities

- Common ECAD Configurations via Options
- Control Flex Region Colors
- New Ribbon Tabs
 - Board Design
 - Assembly Design
- New Collaboration Window
 - Filtering Capabilities

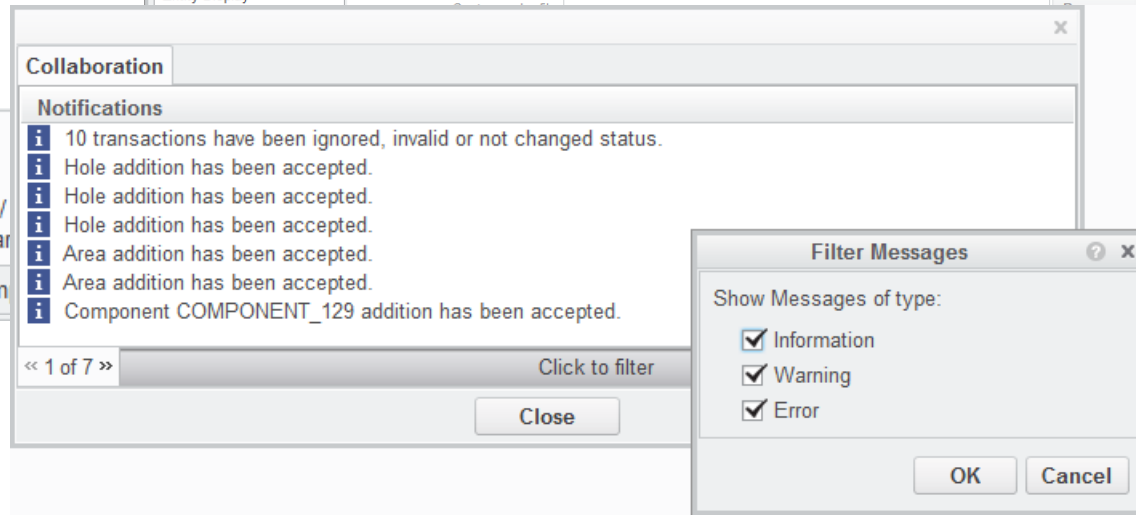
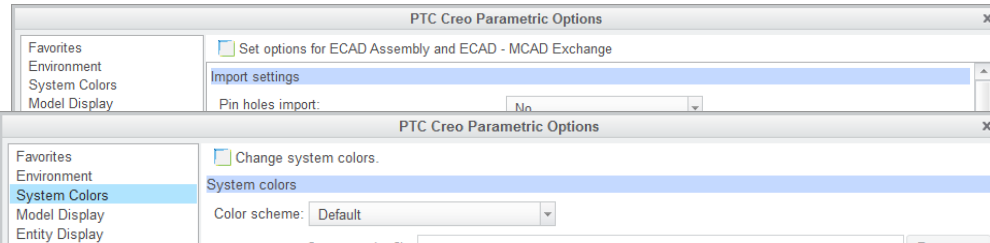
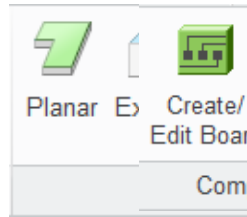

Benefits

- Faster Configuration
- Improved Access to Common Settings
- Consistent User Experience

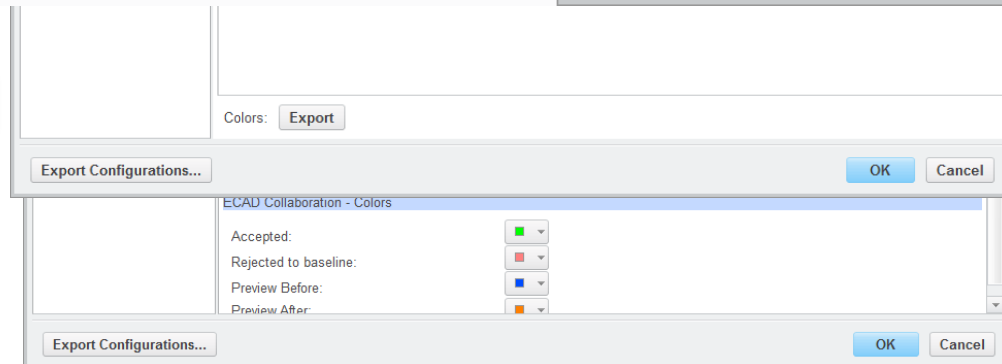

Rigid Flex Boards

Capabilities

- Developed using Proven Sheetmetal Technology
- Flexible Areas
 - Manually created
 - Information Transferred to ECAD
- Bend Information
 - Bend Lines – Automatically Created
 - Bend Areas – Automatically Created
- Component Placement
 - Select Top or Bottom of Board
 - Utilize Drag Handles to Position
- MCAD Board Outline Updates Only

Benefits

- Reduced Training
- Improved Workflows
- Improved ECAD Communication

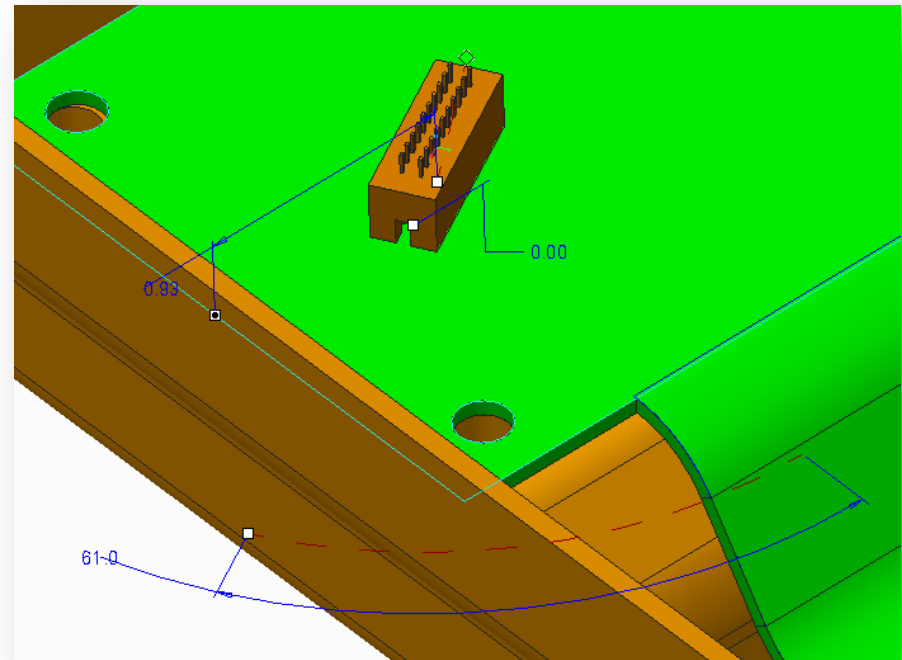

Rigid Flex Boards Continued

Capabilities

- Flat Patten Preview Window
 - Verify NO Overlapping Segments
- Flatten Board or Assembly
 - All Board Features Flatten
 - All Components
- Export IDX in Bent State
 - Board Flattened Under the Hood Prior to Export

Benefits

- Improved Design Accuracy
- Streamlined Workflow

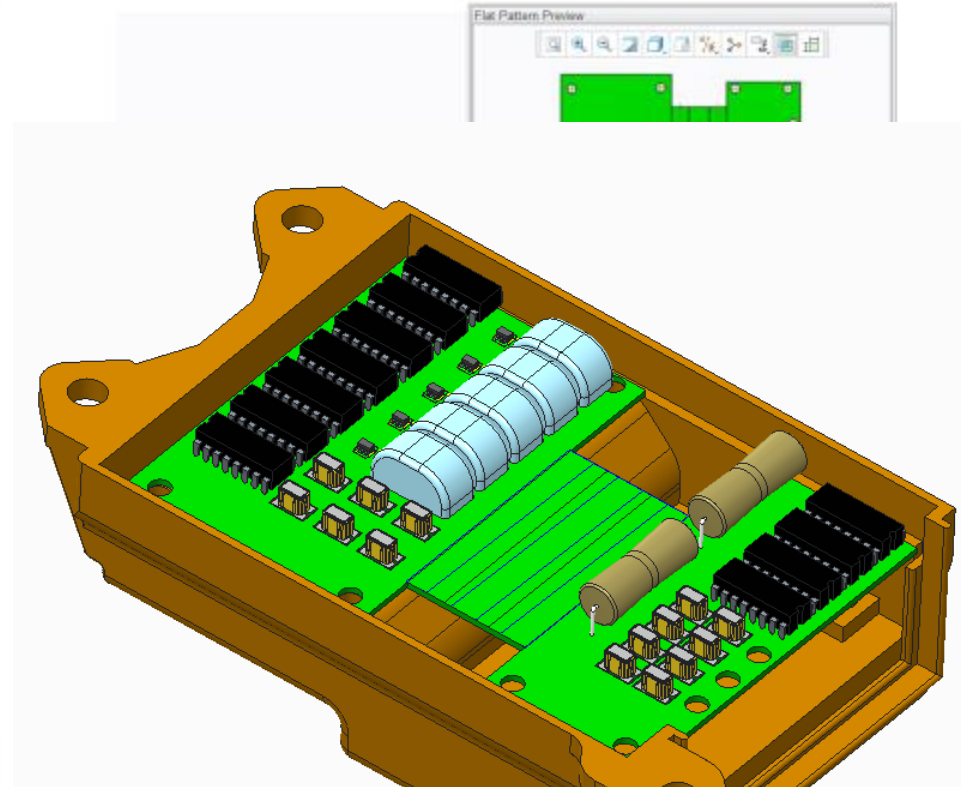

Introduction

Using the traditional harness manufacturing solution to create all the required manufacturing documentation for an average harness would take in excess of two hours.

PTC Harness Manufacturing Extension automates the documentation process reducing the time to less than five minutes.

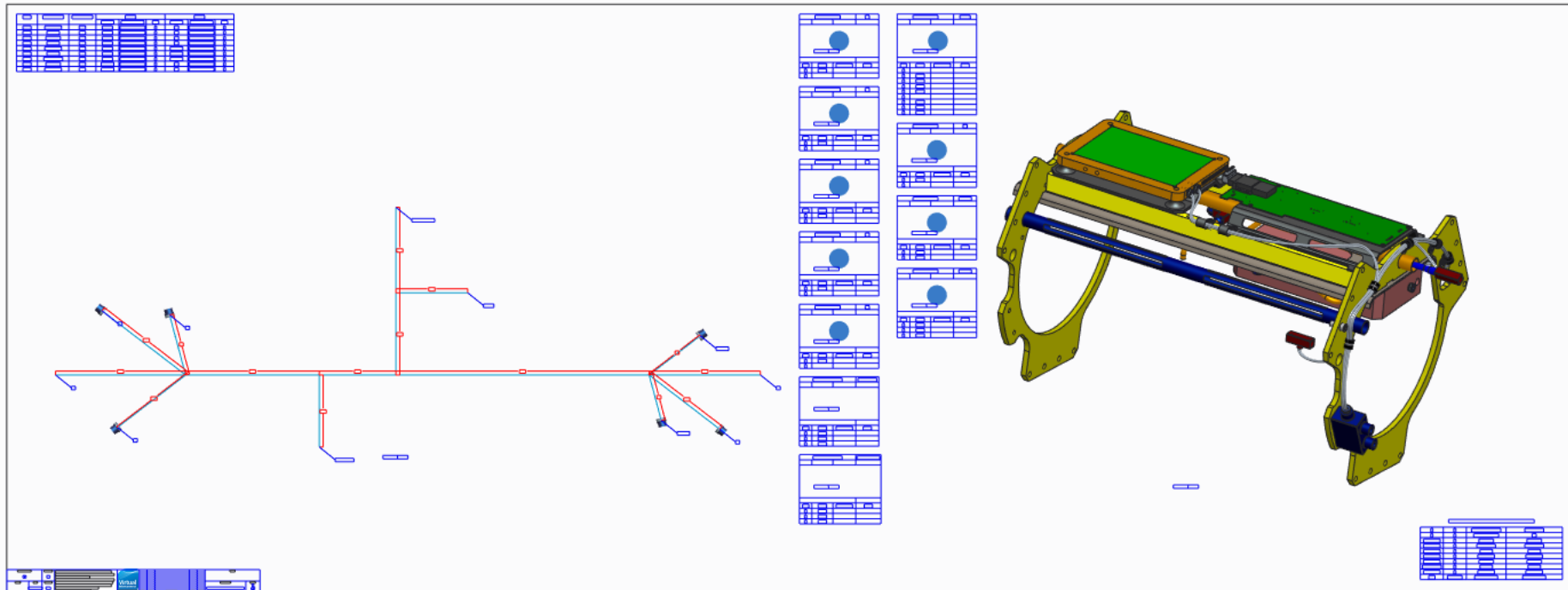

Three Packages Lite, Standard and Advanced

Typical Harness Mfg Documentation Predominantly Aerospace and Defence

	Functionality	Adv
Limitations	Connectors	Unlimited
	Wires	Unlimited
Features	Auto Dimensioning	✓
	Automatic Design Rule Checking	✓
	Back annotation to Creo Schematics	✓
Reporting	Bill of Materials (BOM)	✓
	BOM including spools usage	✓
	BOM including wedges, cavity seals etc	✓
	Wire From/To List	✓
	Cutting List	✓
	Connector Cavity Table including strip length	✓
	Connector Cavity Table including location view	✓

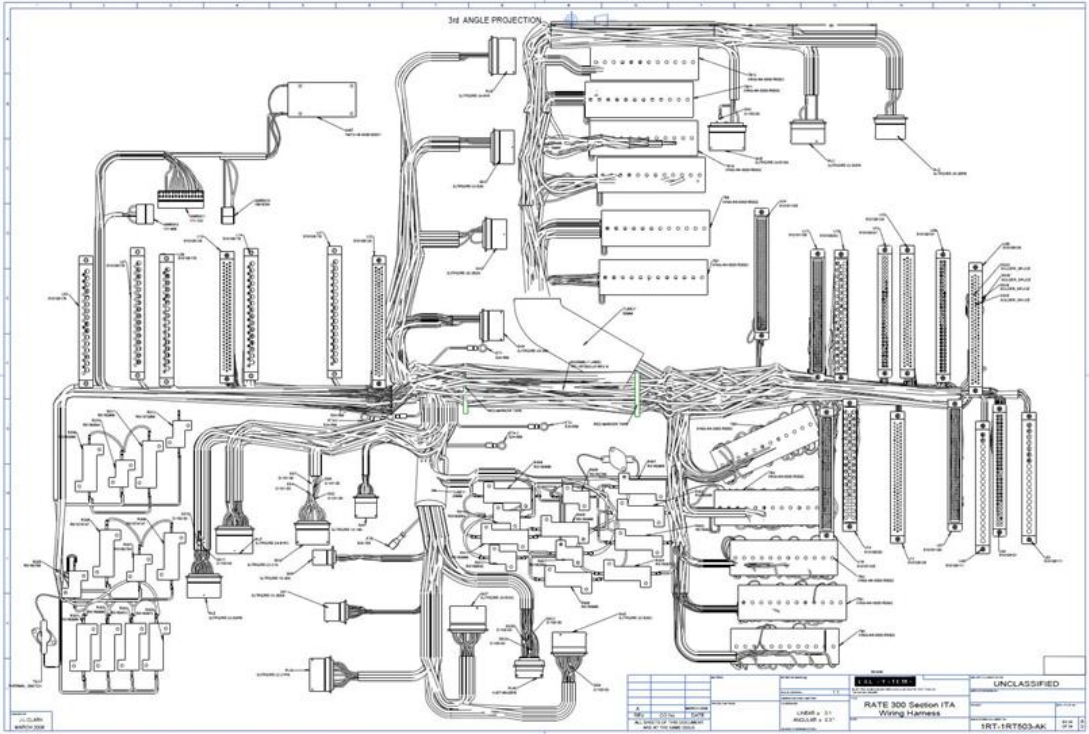

82 Connectors 80 Wires

Creo PMA – ~3 to 4 days to generate

Stick Gen - < 15 minutes

Assuming \$40 hourly rate immediate saving of \$1050 per harness

Standard Sub Assemblies

Capabilities

- Define a Screw Connection
 - Screws are automatically assembled with sub assembly
 - Holes are automatically created in adjoining parts
- Improved Copy Component UI
 - Control Names
 - Control what to copy
 - Automatic selection for Required Part
 - Ignores Standard Components

Benefits

- Improved User Performance
- Enhanced Library Control
- Improved Design Flexibility

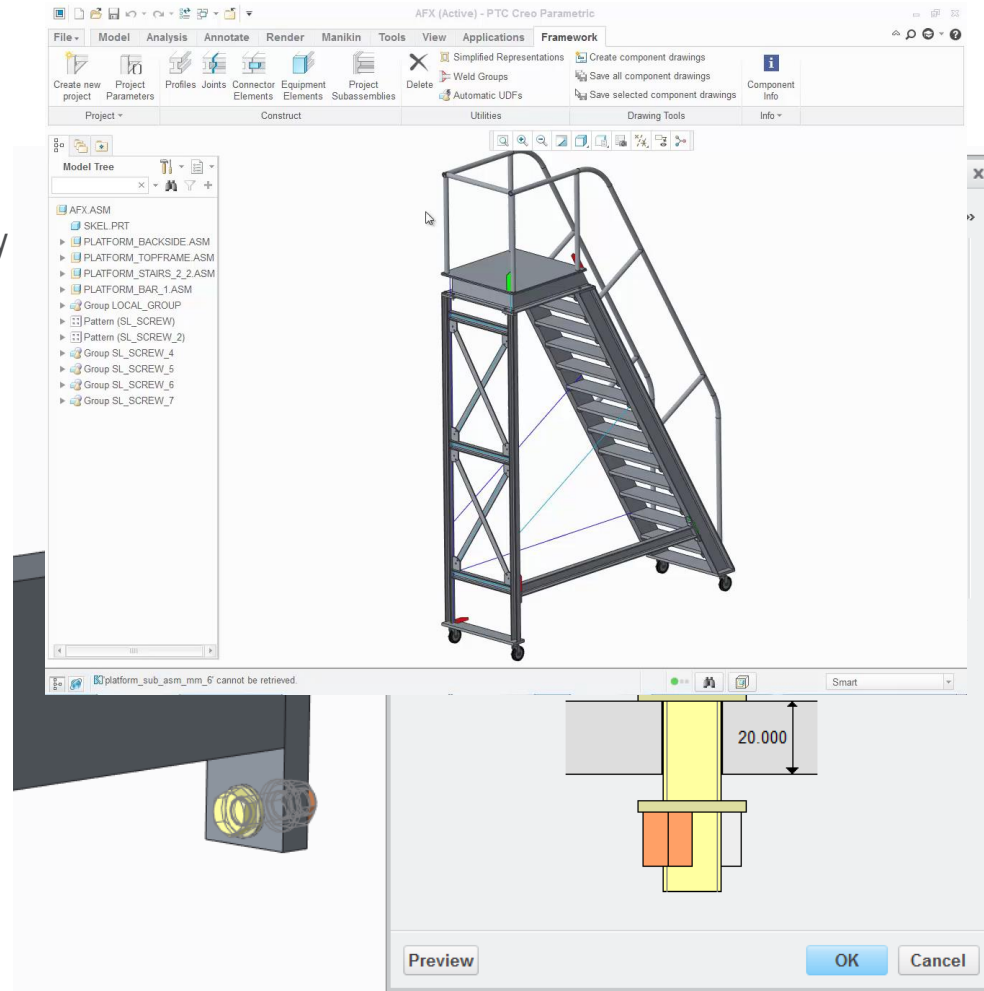

Assembly of Equipment and Connectors

Capabilities

- Improved Reference Selection
 - Select All References in One Action
- New Measurement Capabilities
 - Utilize Measurements During Insertion
 - Two Points
 - Single or Dual Lines
 - Cylinder
- Access Common Commands
 - Profiles
 - Equipment
 - General Manipulation

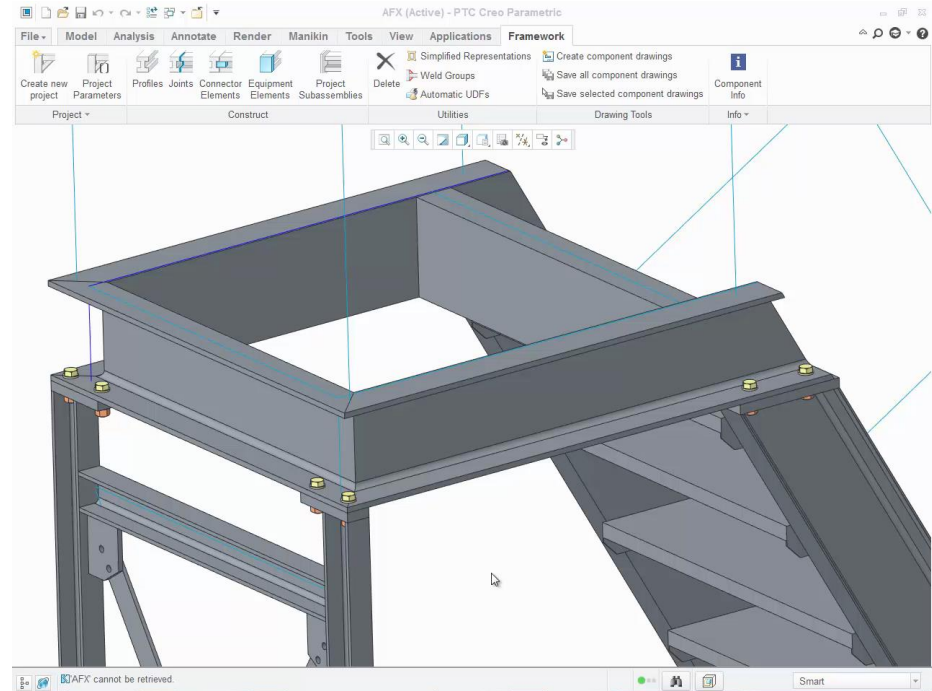

Benefits

- Streamlined Workflow
- Improved User Performance
- Reduced UI Interaction

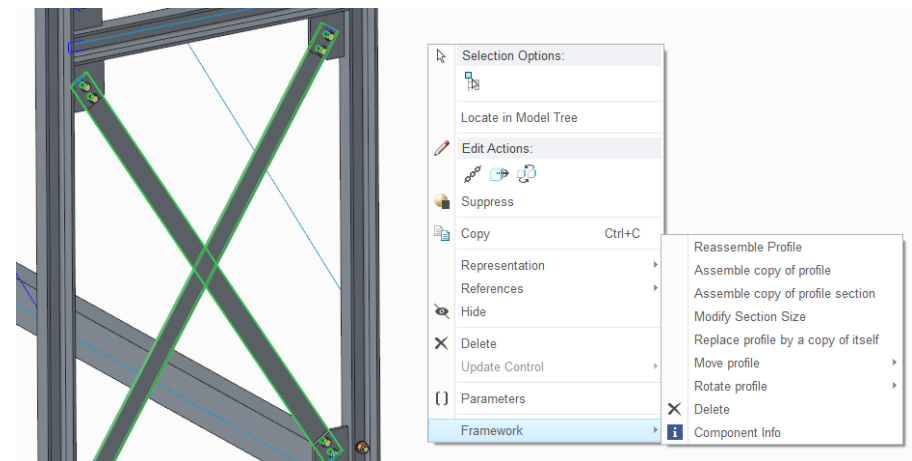

New Dimension Creation UI and Workflow

Capabilities

- Immediate preview of dimension upon selection of references
 - CTRL+select to choose additional references
- Improved workflow for creating common reference dimensions
- Dimension options accessible from right mouse button pull-down

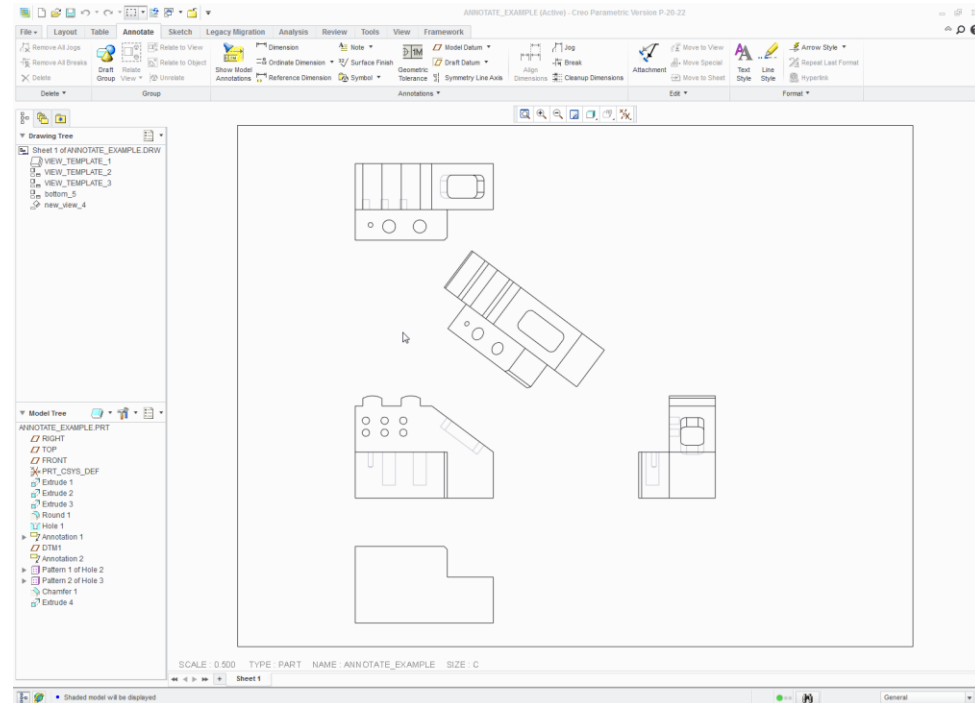

Benefits

- Create dimensions faster
- Better visual feedback during dimension creation

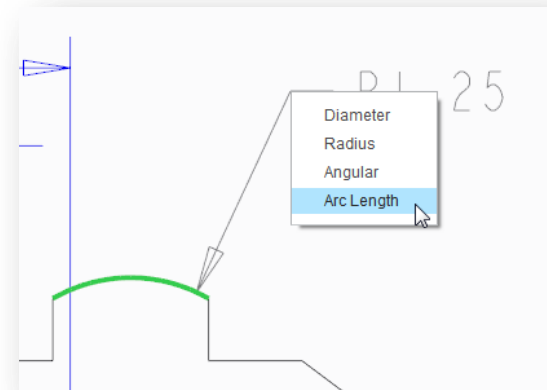

New Print and Preview UI

Capabilities

- Consolidated Print and Print Preview Tab
- Quick and easy access to all print configuration options
- Accurate preview of the printed output

Benefits

- Streamlined process for printing drawings

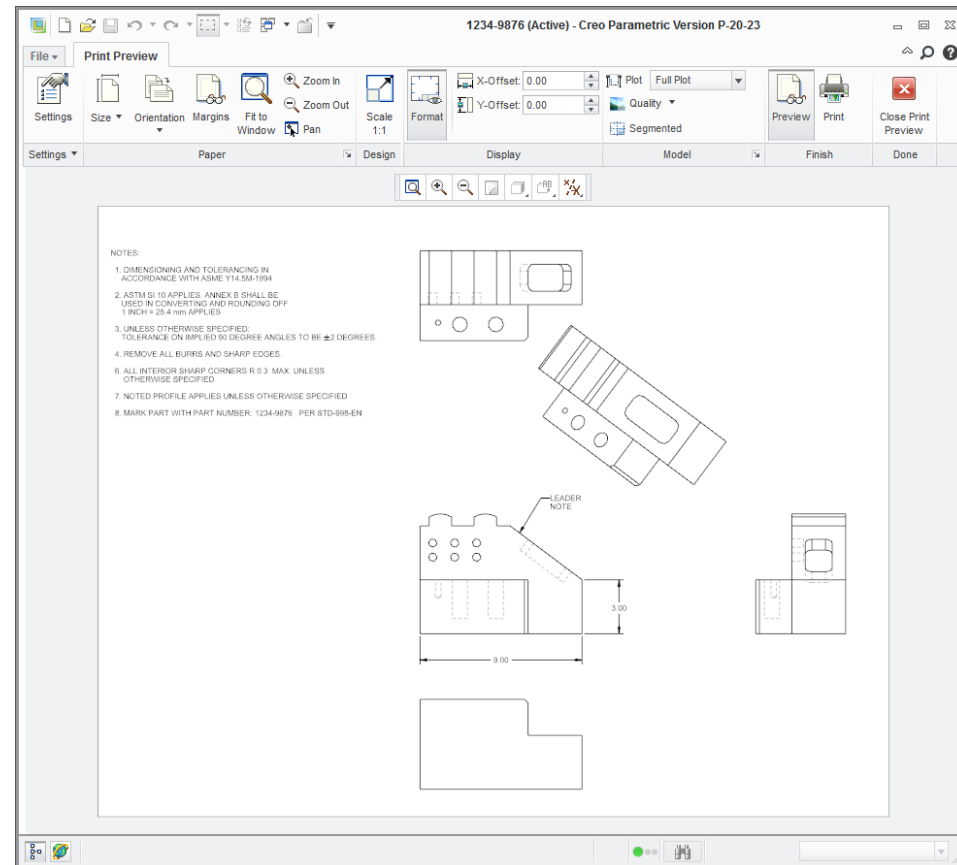

New Note Creation UI and New Format Tab

Capabilities

- Dynamic preview of notes including leader attachments
- On-screen editing of note text
- New Format tab for editing note properties
- Add parameter fields by picking from a list of standard parameters

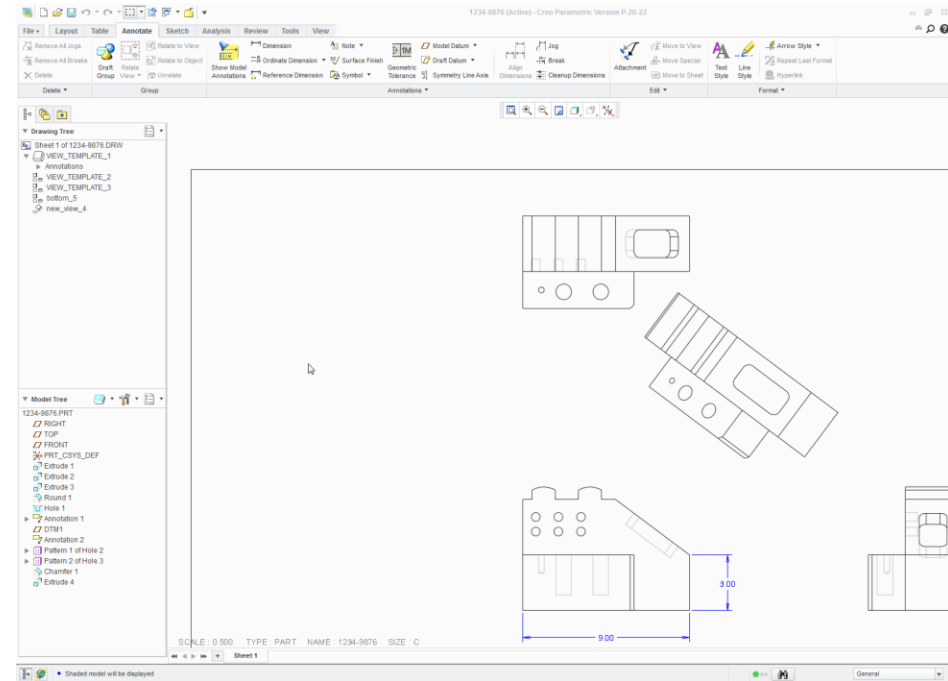

Benefits

- Create notes faster
- Better visual feedback during note creation and editing

Drawing Standards Improvements

Capabilities

- ASME Y14.5-2009
 - All Over modifier for surface profile tolerances
 - Translation modifier for datums
 - Placement of datum tags
- ASME Y14.41-2003
 - Ability to designate a note as a security marking
 - Allow symbols to be called out in 3D notes
 - Allow hyperlinks to combined states
- ISO
 - Allow additional text below and on left of GD&T frame
 - Allow additional text above or below a GD&T frame to be justified horizontally
 - Reciprocity modifier for datums

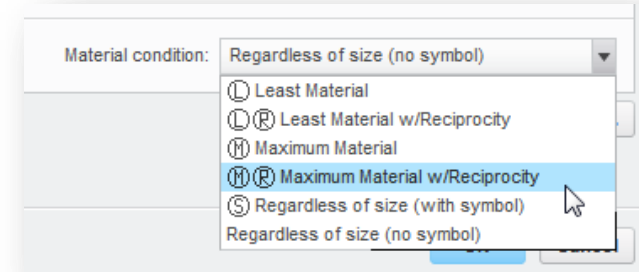
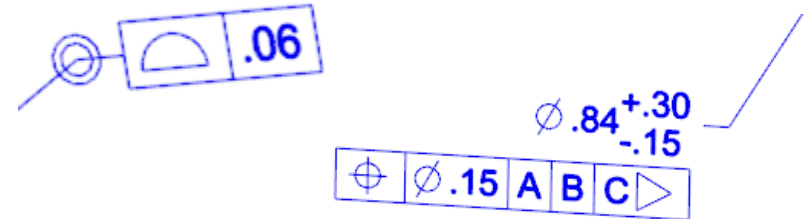

Benefits

- Improved compliance with industry standards

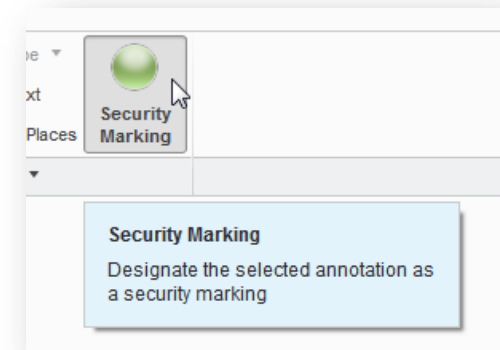

Support Models with Failed Features

Capabilities

- Users will now have the ability to define, modify and analyze models containing failed features
 - As with PMA, all failed features will be shown in Red in the model tree
- Users will be presented with a warning message indicating the model has failed to regenerate
 - Traffic light shows red at the bottom of the screen
- Users will be limited to running analyses or standard design studies
 - Sensitivity or optimization design studies will not be available if the model has failed features

Benefits

- Improved productivity and user experience
- Users do not need to resolve failed features to access Creo Simulate

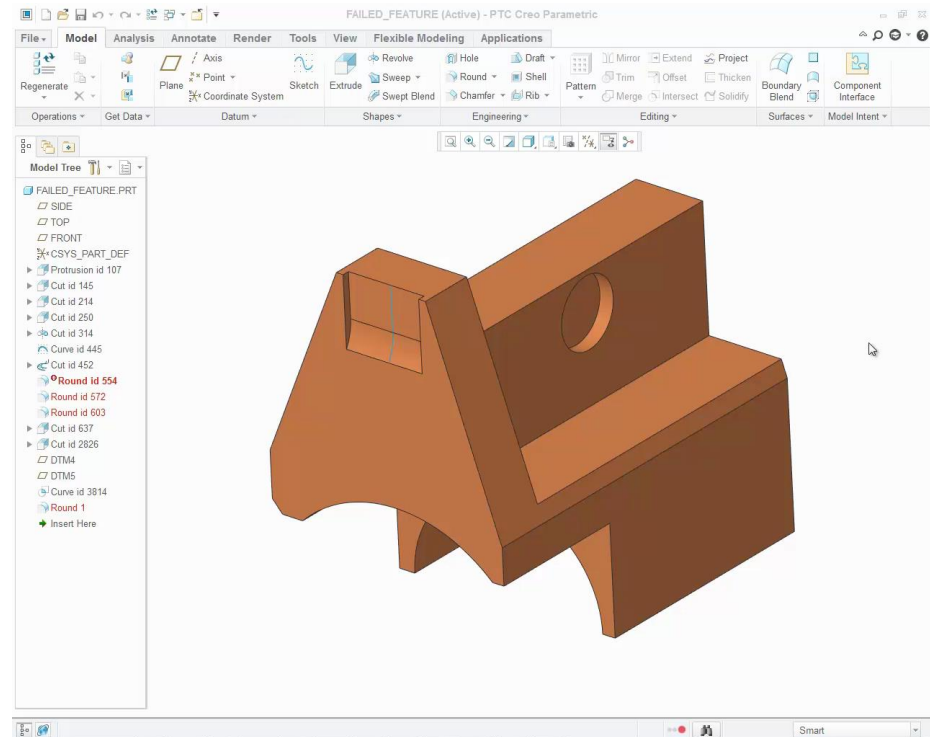

Improved Object Display

Capabilities

- Idealizations
 - Shells
 - Thickness displayed when user selects the shell
 - Beams
- Connections
 - Fasteners
- Objects will be shown as transparent
 - Users can change the display to wireframe or solid via the Simulation Display dialog
 - Config option control:
 - `sim_display_fasteners_mode` = wireframe/transparent/shaded
 - `sim_display_beams_mode` = wireframe/transparent/shaded
 - `sim_display_shells_mode` = wireframe/transparent/shaded

Benefits

- Improved visualization
- Improved productivity and user experience

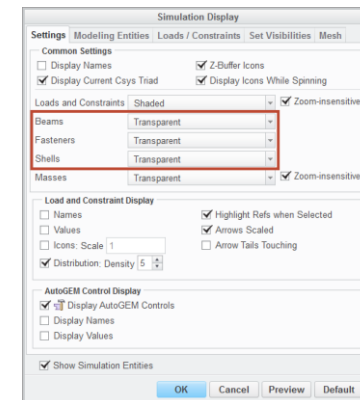
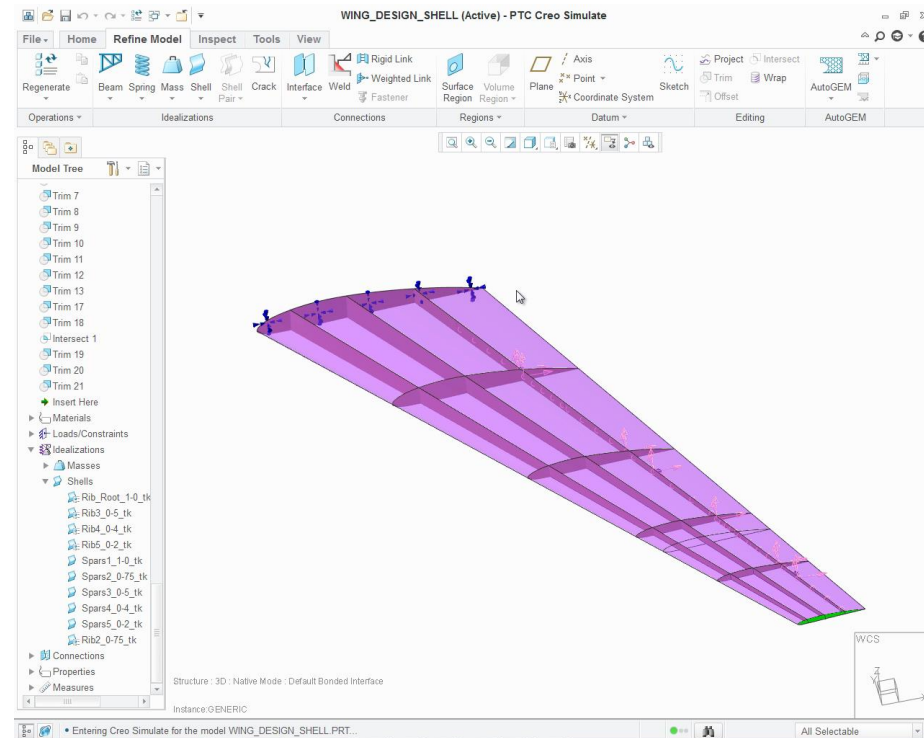

Productivity Improvements

Capabilities

- **Diagnostics enhancements**
 - Warning when nonlinear effects may be important
 - Warning when properties vary widely – typo / wrong units?
- **Analyses as nodes of Model Tree**
 - Set the Tree Filters Option to display Structure and Thermal entities together
- **Updated Material Orientation, Note UI**
 - Same as PMA – does not require users to specify placement
- **Unicode support**
 - Multi-language support for entity names

Benefits

- Provide users tips on improving their results
- Easy display of Analyses saved in the model
- Productivity Improvements

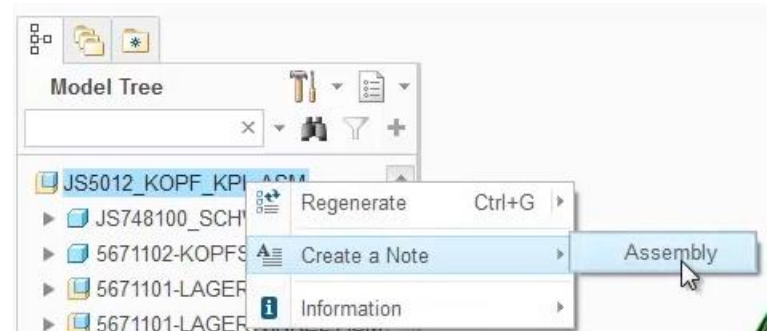
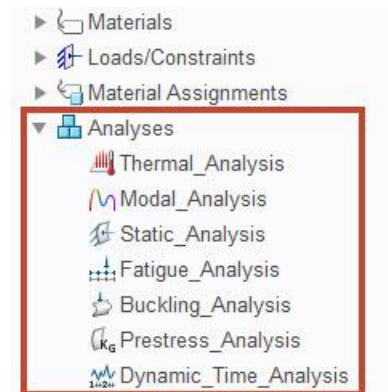
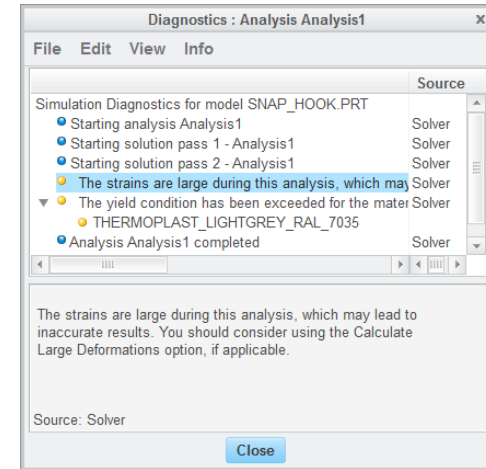

Sliding Contact with Friction

Capabilities

- Users can apply a finite friction contact interface between two surfaces or components
 - Applies for both 2D and 3D Models
 - Performs a nonlinear large displacement analysis
 - Requires Simulate Advanced License
- Users are able to specify define different values for Static and Dynamic coefficients
- Maximum Tangential Traction per contact interface is calculated as an automatic measure – in addition to normal force, contact area and the slippage coefficients
 - <INTERFACE#>_tang_force

Benefits

- Determine if sliding has occurred between components
- Determine the tangential force load transferred across each interface
- Improved analysis results

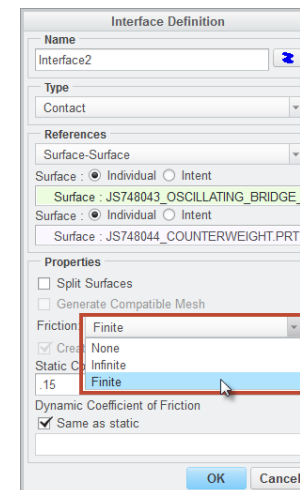
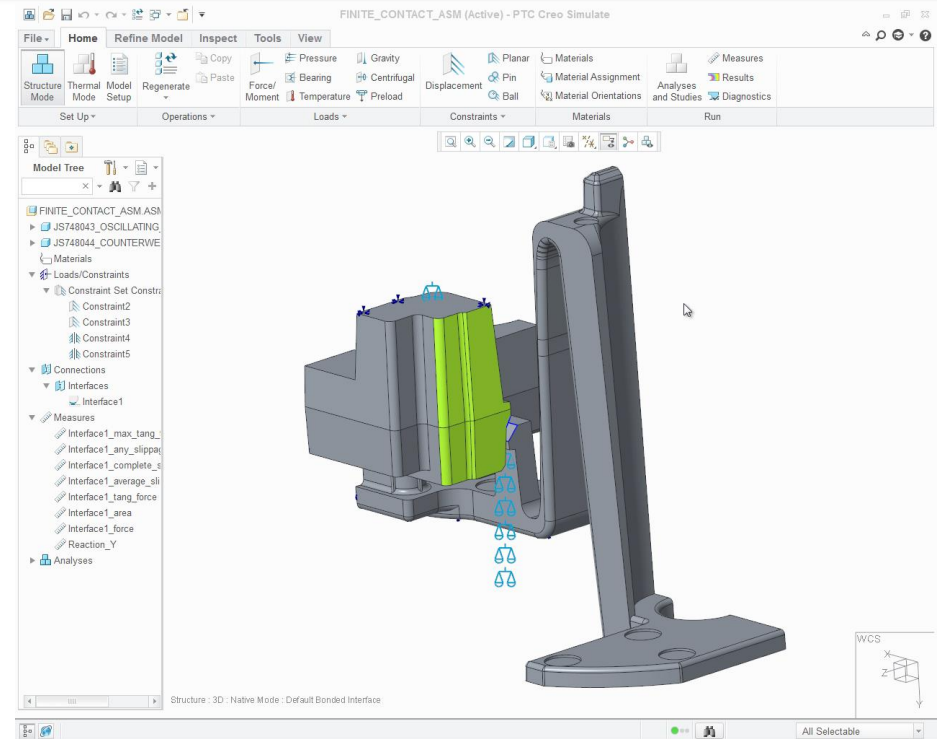

Fracture Mechanics

Capabilities

- New Crack Idealization available in both Structure and Thermal modes
 - Select curve references for 2D models and individual surfaces for 3D models
- Simulate checks are introduced to evaluate if there is a crack that cuts through the entire model.
 - If so, a warning appears in the Diagnostics dialog box for the analysis.
- New measure - Stress Intensity Factor
 - Mode I (Opening) for 2D models
 - Mode II (Sliding) for 2D models
 - Mode III (Tearing) for 3D models

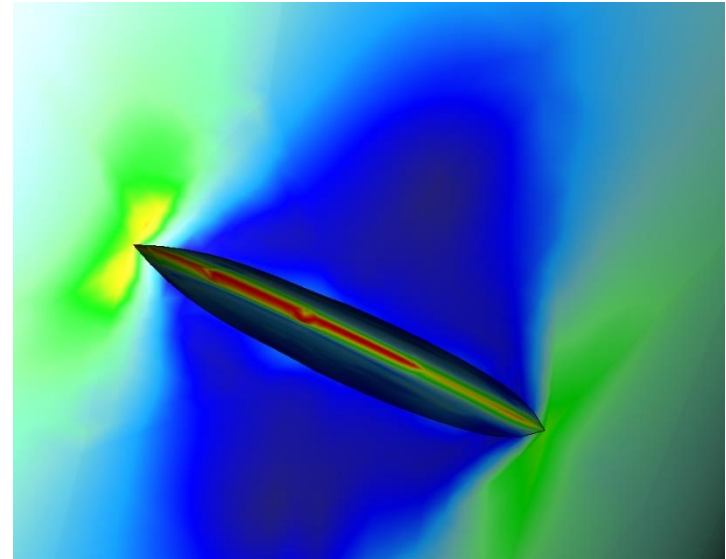

Benefits

- Determine if initial cracks in your model will grow under specified loading conditions
- More predictable results

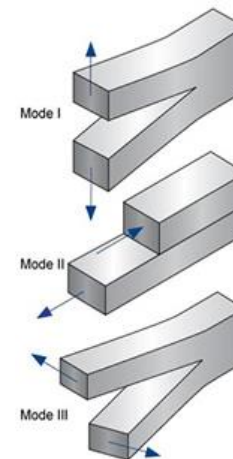

Fastener Preload

Capabilities

- More accurate preload modeling
 - Requires Simulate Advanced License
- Account for the stiffness of the structure
- Automatically iterate with scaled loads to achieve fastener preloads at target values

Benefits

- Preload force is applied to the deformed model providing more predictable results
- Reduces the need for users to manually calculate and scale the preload force

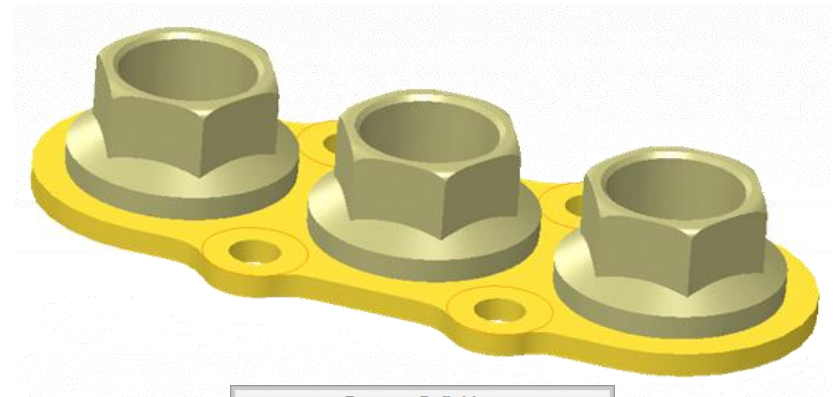

Fastener Definition

Name: Fastener1

Connecting Solids: [Dropdown]

Fastener Type: Screw

References

Edge: Edge : P2.PRT

Edge: Edge : P2.PRT

Properties

Stiffness: Using diameter and material

Diameter: 26 mm

Material: STEEL More...

Fastener Head and Nut Diameter: 44.2 mm

Fix Separation Frictionless Interface

Separation Test Diameter: 52 mm

Include Preload Account for Stiffness

Preload Force: 500 N

OK Cancel

Productivity Improvements

Capabilities

- **New Simulation Feature type: Split Surface**
 - Functionality also available in Creo Parametric
 - Creates new surface from a single contour of multi-contour surface
 - Similar to Surface Region
- **Ball, Planar, Pin Constraints in LDA**
 - Extending capability that is available in SDA
- **Weighted links for 2D analyses**
 - Extending capability available in 3D mode

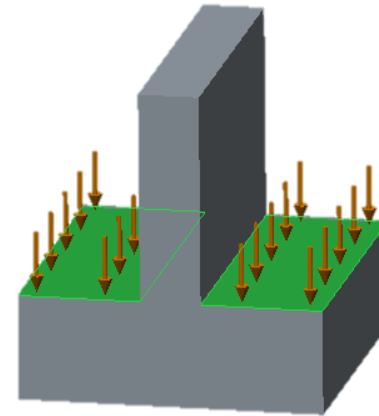

Benefits

- Enables the ability to apply different loads/constraints to the model without the need to remodel the geometry
- Extends functionality to other areas of Creo Simulate providing flexibility for users

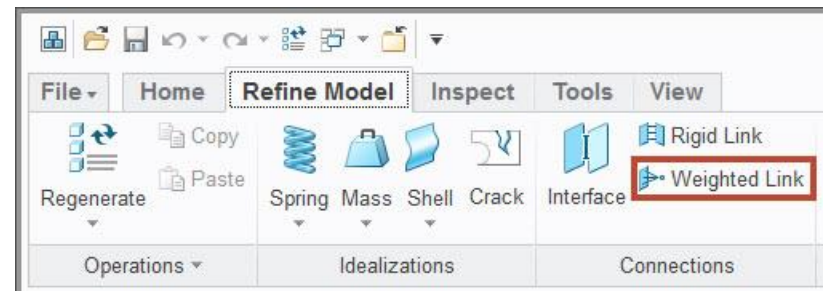

Productivity Improvements

Capabilities

- Interpolated loads
 - Functionality as in Native mode
- Solid-shell links
 - Automatic hinge removal at the transition between solids and shells
 - Functionality already available in Native mode
- TLAPS
 - Total Load at Point functionality as in Native mode
- Updated Ansys and Nastran Solver versions
 - Providing support for Ansys 14.5 and Nastran 2012
- Ansys tapered shells
 - Functionality already available through Nastran

Benefits

- Extends functionality to other areas of Creo Simulate providing flexibility for users

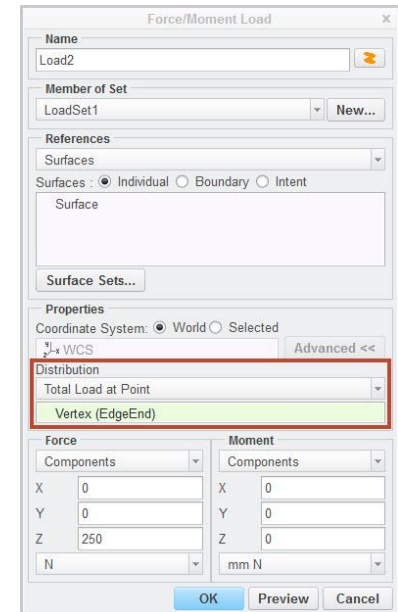
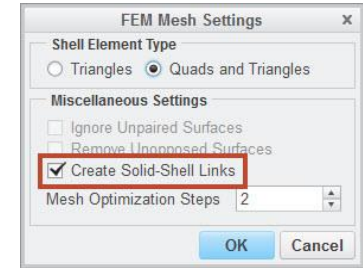
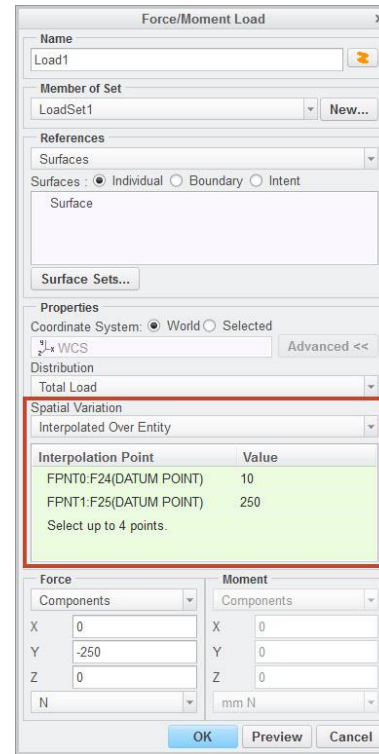

Mapped Meshing for 2D models

Capabilities

- Structured meshes of quads and tris in 2D models
- Automatic transition to unstructured mesh regions
- Helpful for the following conditions:
 - If you have 2D models with contact interfaces where the accuracy of the calculated pressure is dependent on the refinement of the mesh in the contact area
 - When performing a large deformation analysis
 - On models with elastoplastic/hyperelastic material

Benefits

- Extends functionality to 2D plane stress, plain strain, and axisymmetric models

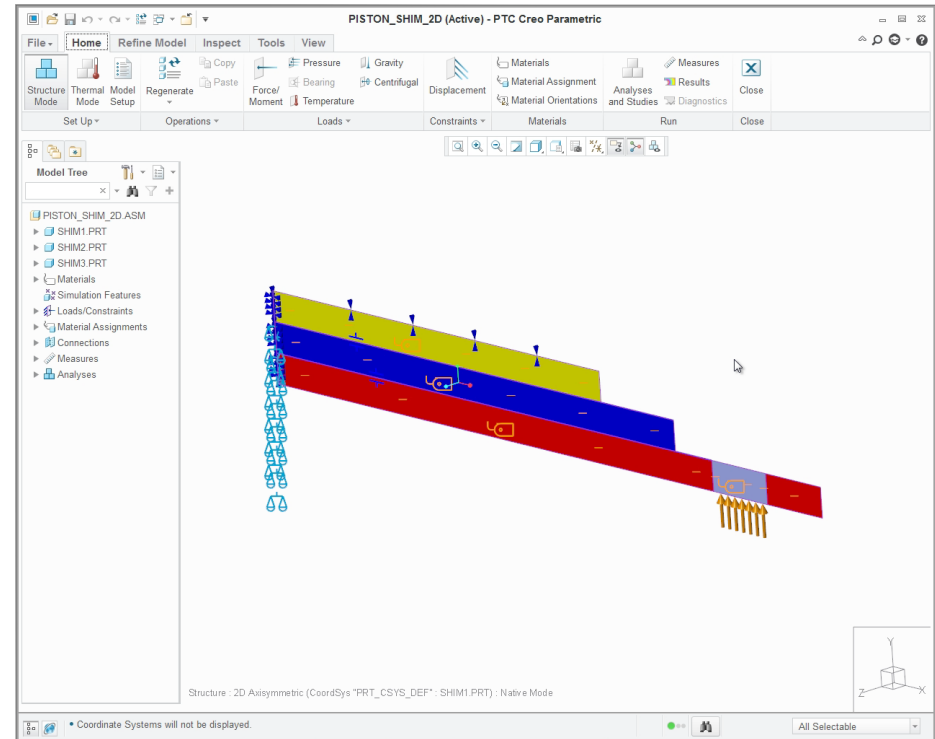

Multiple Load Sets

Capabilities

- Multi-load effects with independent histories
- Use of the latest solver from nCode with updated models

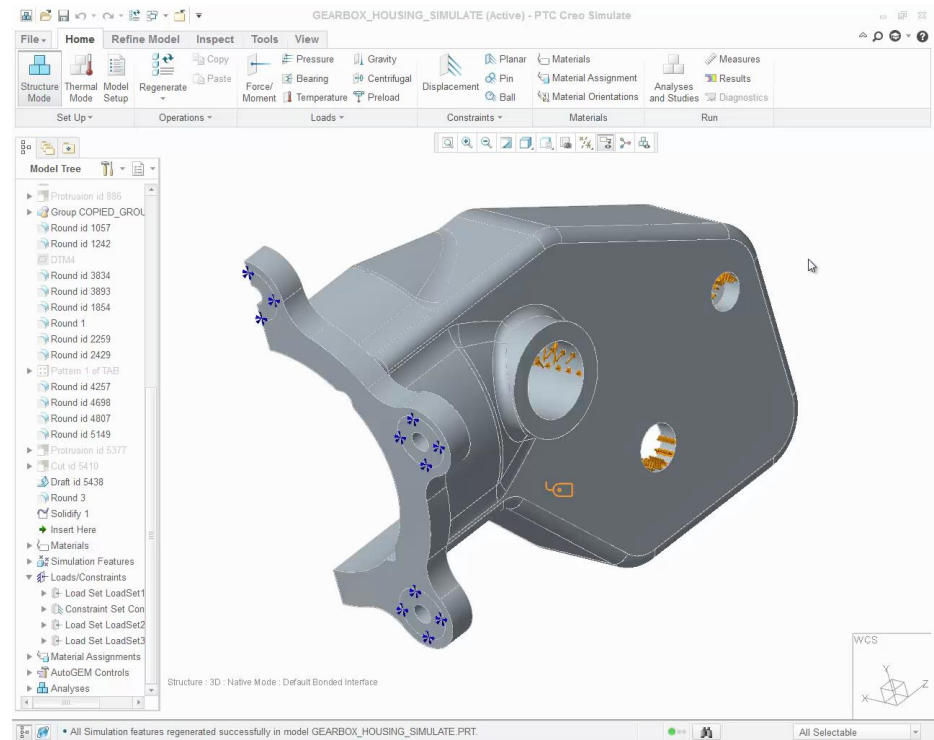

Benefits

- Users can properly group loads logically in their model and use them for the fatigue analysis
- Select which load groups to include in the analysis

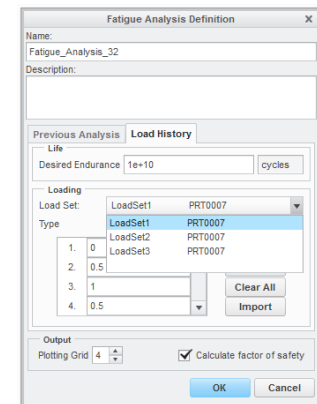
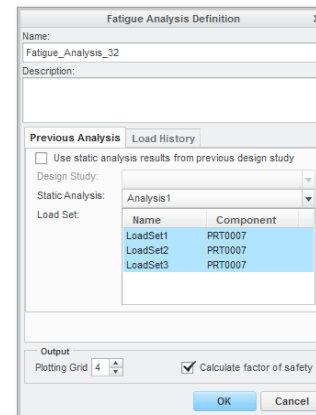

Simulate Results Window

Capabilities

- Optimized ribbon UI
- General window management
- Dynamic editing of quantity and legend levels
- Easy access of commands through context sensitive pop-up menus

Benefits

- Improved productivity and user experience
- Standardized ribbon UI makes it easy to use and for new users, easier to learn
- Select common commands directly within the Graphics window

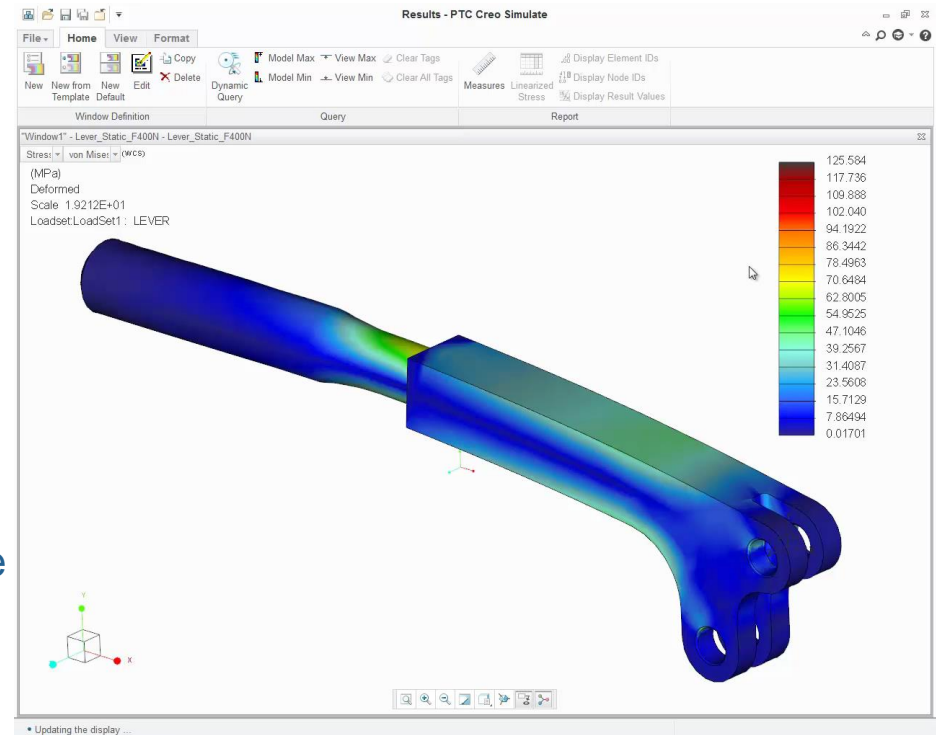
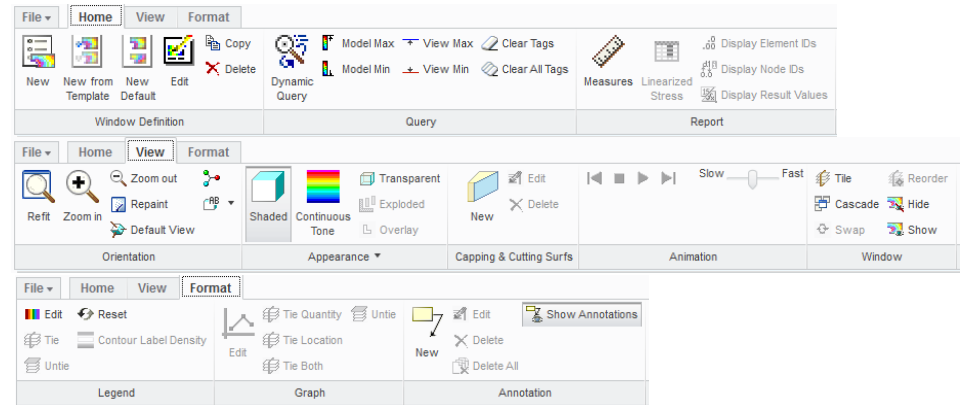

Linearized Stress Results

Capabilities

- Location selected on geometry, not tied to plotting grid
- Powerful, automatic methods to select direction of cross-section and basis
- Clear, graphical display of components
 - **Membrane** - Overall average stress
 - **Bending** - The difference in the stress from the inside point to the outside point
 - **Mem+Bend** - The sum of the **Membrane** and **Bending** numbers
 - **Peak** - The highest stress found along the line

Benefits

- Improved productivity and user experience
- Easily selection of reference on the model

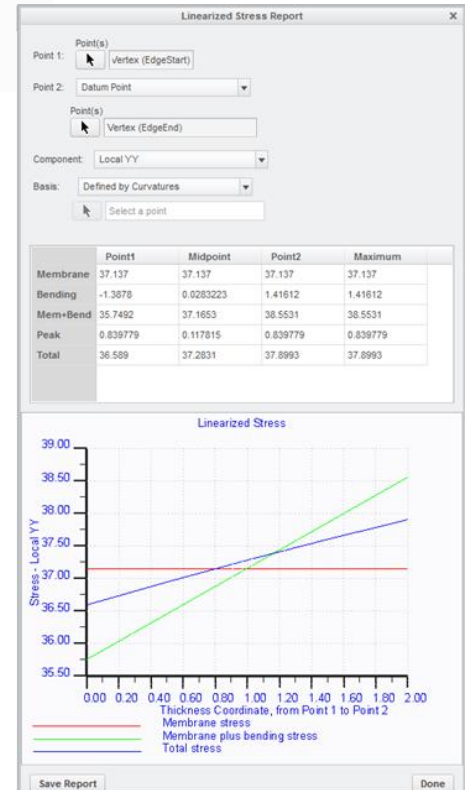
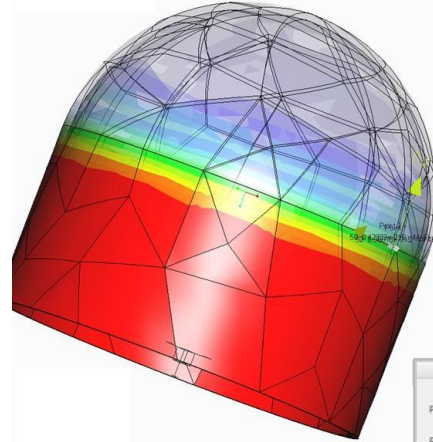

PTC Creo 3.0 F000

- SolidWorks, CATIA, NX & Inventor Import
- Collaboration Extensions for SolidWorks, CATIA, NX

PTC Creo 3.0 M010

- Solid Edge Import
- New PTC Creo Mold Analysis Extension

PTC Creo 3.0 M020

- File-Open, Conversion on Demand
- Enhanced Update for SolidWorks, CATIA, & NX
- Enhanced PTC Mathcad Integration



PTC Creo Elements/Direct 19.0

PTC Windchill 10.2 M030
Support for Enhanced Workflows Shipped with PTC Creo M030

- PTC Creo 3.0 Platform Support:
 - Windows 7 32-bit and 64-bit OS
 - Windows 8 32-bit and 64-bit OS
 - Windows 8 & 8.1 Update 32-bit and 64-bit OS
- PTC Windchill Compatibility²:
 - PTC Windchill 10.1 M040+
 - PTC Windchill 10.2 M020+
 - PTC Windchill 10.2 M030+: Enhanced PTC Creo 3.0 M020 Workflows
- Virtualized Desktop Environments¹
 - GPU pass-through on Citrix XenServer 6.2 SP1 and XenDesktop 7.5
 - **NEW! vGPU** on Citrix XenServer 6.2 SP1 and XenDesktop 7.5
- PTC Creo Sketch 3.0
 - Mac OSX
 - **NEW! iOS (iPad)**

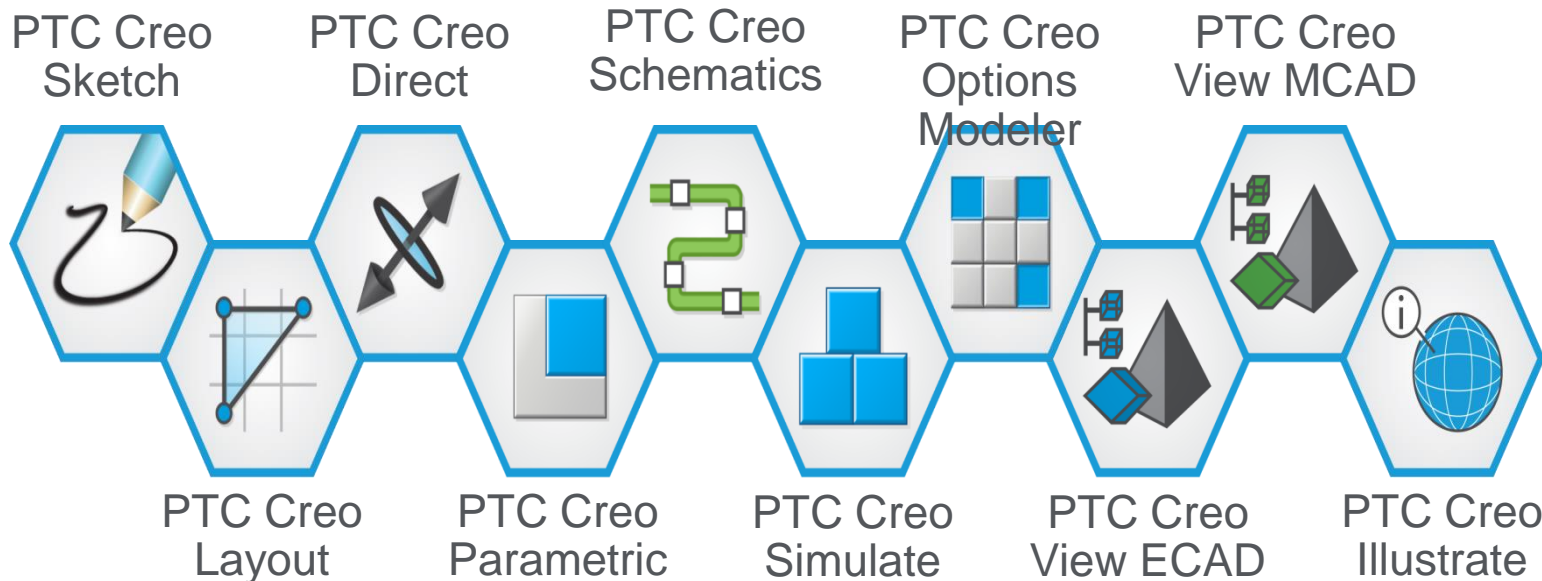

1. Visit platform support page for more details on certified configurations.

2. PTC Creo Sketch is not

3D Printing

.....
Dedicated environment to prepare models for 3D printing:

- Identify and resolve 3D printing-specific issues
- Integrated smart positioning tools
- Automated Support Structure Creation

App & Extension Development Tools

.....
Build “PTC Creo Certified” Apps & Extensions

- Extend existing PTC Creo App family
- Reuse existing PTC Creo extension code
- Partner extensions/apps certified directly with PTC Creo R&D

Graphics & Assembly Performance

.....
Breakthroughs to deliver immersive, high-performance environments:

- Continued Real-time, realistic materials
- Modular Regeneration for Massive Assemblies
- Common Lightweight Graphics



And More...

New Selection Paradigms
Alternative, Innovative UI Approaches



Available on PTC.com

- 3rd Party Analyst's resources:
Chad Jackson, Lifecycle Insights:
[eBook CAD Consolidation: Rewriting the Rules of Design Exchange](#)
Jim Brown, Tech-Clarity:
[CAD consolidation Kit](#), includes two separate reports outlining the significant savings from consolidation, and calculate actual savings with included worksheets.
- Online product demo
[CAD consolidation with PTC Creo](#)
- Customer references, 3rd party coverage, and PTC views:
<http://creo.ptc.com/tag/consolidate/>
- Multi-CAD Design website:
<http://www.ptc.com/product-design-challenge/multi-cad/>

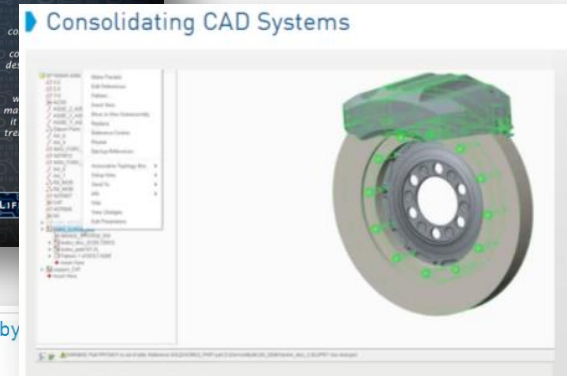

Sió-Metál Halves Development Time by Consolidating on PTC Creo

By GEOFF HEDGES | Published: JAN 9, 2014

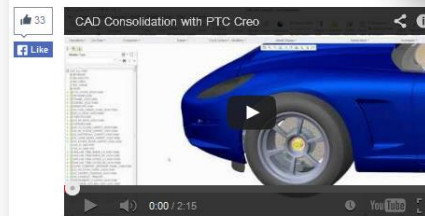

Here's a New Year's resolution that worked out very well: Thirteen-year-old Sió-Metál, L recently committed to consolidate its CAD processes. The Hungarian company makes

Calculating Your Savings for CAD Consolidation

Free CAD Consolidation Kit

As a user of multiple in-house CAD systems, you're probably already aware of the challenges. But do you really know how much time and money you can save by moving to one CAD system?

If you're on the fence about CAD consolidation or want to make a case to your company, this kit is for you. Tech-Clarity analyst Jim Brown, in two separate reports, outlines how significant savings come from consolidating either your 3D CAD software or all your CAD software (2D, 3D, and PDM) into one suite. Feel free to download the reports with included worksheets.

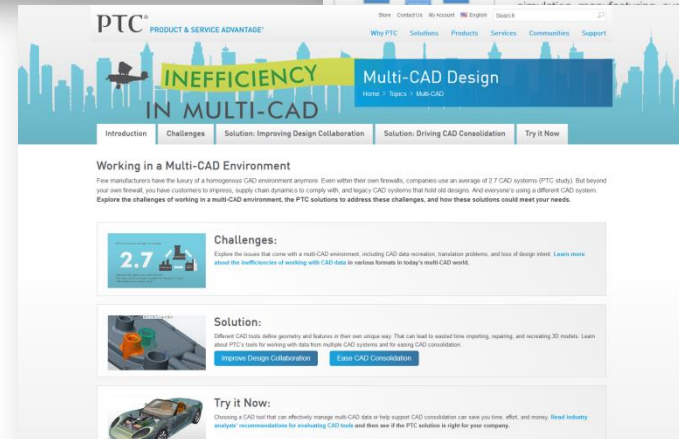



2014 Annual Support Enhancements

PTC prides itself in delivering a comprehensive support experience designed to maximize productivity, optimize system capability and performance, control costs, reduce risk, and optimize price. Here's a look at the enhancements made since June of 2013:

Software Support

Software Releases – 26 Major Releases

PTC CAD Products and Related Applications

- PTC Creo 3.0
Includes Parametric, Direct, Simulate, & Layout
- PTC Creo/Elements Direct 19.0
- PTC Creo Illustrate 3.0
- PTC Creo View & View Adapters 3.0
- PTC CADD5 16.1
- PTC Optegra 16.1

PTC Windchill

- PTC Windchill 10.2
Includes PDMLink, ProjectLink, Pro/INTRALINK, PDM Es essentials, Service Information Manager/Service Parts, Product Analytics and Quality Solutions
- PTC System Monitor 3.0

PTC Arbortext

- PTC Arbortext Editor & Digital Media Publisher 6.1
- PTC Arbortext Content Manager 10.2
- PTC Service Center 10.1

PTC Mathcad

- PTC Mathcad Prime 3.0

PTC Integrity 10.5 & PTC Implementer 11.0

Software Releases - 139 Maintenance Releases

PTC Creo and CAD related applications

- 60 Maintenance Releases

PTC Windchill & PLM Extended

- 55 Maintenance Releases

PTC Arbortext

- 24 Maintenance Releases

SLM Releases & Support Enhancements

For all PTC Servigistics enhancements [CLICK HERE](#)

sSupport

NEW Any-Device Access

Access your eSupport Portal at any time from anywhere from your smartphone, iPad, or tablet.

Award Winning eSupport Portal 2013 & 2014 ASP Award Winner

Increased Personalization & Customization for quick, easy navigation. Features include:



Intelligent Case Management

- My Cases Portlet
- My Company Portlet
- My Company's Customer Environment Profiles Portlet
- My Company's Projects Portlet (for Platinum customers)

Self-Guided Support

- My Bookmark Portlet
- My Recently Viewed Documents Portlet
- My Pending Activity Portlet
- Recommended Articles

Better Search

- Find the best answers and results for your search queries – even if your search keywords are not exact
- Highest ranking articles appear first; those rated best by other customers and re-use from PTC Technical Support

Improvements to Web Tools and Resources

- Updated, streamlined Case Logger web tool for more efficient case creation
- New License Management page and self-help resources
- Refreshed "My Account" interface with more self-help resources

Proactive Support Alerts

- *The Support Advisor* – monthly eAlert for Support customers
- Twitter Feed - Follow us: "PTC_Support"

Assisted Support

GOLD Support Desk

- **NEW Portuguese Language Support** – resources & infrastructure in place
- PTC Acquired Products (PTC Servigistics, PTC Enigma, and ThingWorx) integrated into the Technical Support Team
- Increased the number of Technical Support Engineers (TSEs) Globally

PLATINUM Support Desk

- Clearly defined mechanisms for Production vs. Project Centric Support Features
- Increased focus on High-impact Enterprise Support Needs
- Increased the number of Technical Support Engineers (TSEs) in North America and Europe

Weekend Support

- **NEW** Dedicated Weekend Team
- Updated Critical and Planned Support Features
- Updated Supported Products & Service Level Targets

PTC Partner Support (*Selected Partners Only*)

- **NEW** Support Services to help Partners' customers
 - Partner Support Desk
 - Partner Relations Manager (PRM)
 - Partner Technical Workshops

ISO 9001: 2008

- Quality Management System Certified for 15 continuous years

Online Customer Support Guide

- Comprehensive information about PTC Support packages, policies and procedures

PTC University Deutschland – Österreich - Schweiz

- Wir bieten PTC Creo Schulungen für Anwender jeden Kenntnisstands
- Sie können zwischen verschiedenen Trainingsformaten wählen oder wir stellen Ihnen ein für Ihr Unternehmen massgeschneidertes Programm zusammen
- Vereinbaren Sie noch heute ein unverbindliches Gespräch mit unseren Schulungsberatern:



Annika Kruse

Beratung Schulungen

PTC University Deutschland, Österreich, Schweiz

<http://www.ptc.com/go/training-advisor>

+49 (0)89 32106 458

PTC[®]

PRODUCT & SERVICE
ADVANTAGE